

# MentalModeler v0.2

Steven Gray, Alexander Metzger,  
Steven Scyphers, and Antonie Jetter



# MentalModeler v0.2

www.mentalmodeler.org

MentalModeler

01 HOME

02 DOWNLOAD

03 WHAT IS FCM?

04 RESOURCES

05 ABOUT

01 HOME

## What is *Mental Modeler*?

*Mental Modeler* is modeling software that helps individuals and communities capture their knowledge in a standardized format that can be used for scenario analysis.

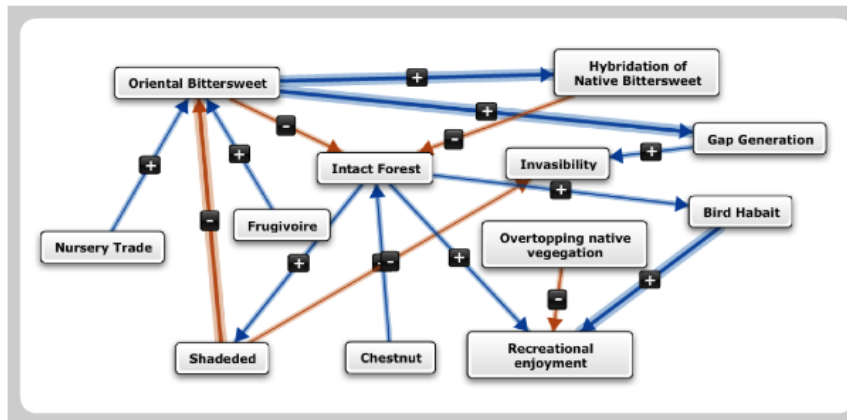

Based in Fuzzy-logic Cognitive Mapping (FCM), users can easily develop semi-quantitative models of environmental issues, social concerns or social-ecological systems in *Mental Modeler* by:

- Defining the important components of a system
- Defining the relationships between these components
- Running "what if" scenarios to determine how the system might react under a range of possible changes.

# MentalModeler v0.2

## Design Goals:

- **Represent** and **standardize** stakeholder knowledge and values in resource decision-making
- Provide flexibility and ease in the modeling process
- Create datasets which can compare and combine stakeholder understanding and values
- Create datasets which can be integrated with expert knowledge, scientific datasets, and used to test co-developed hypotheses
- Increase understanding of the structure and function of social-ecological systems

# MentalModeler v0.2

## Design Goals:

- Represent and standardize stakeholder knowledge and values in resource decision-making
- Provide **flexibility and ease** in the modeling process
- Create datasets which can compare and combine stakeholder understanding and values
- Create datasets which can be integrated with expert knowledge, scientific datasets, and used to test co-developed hypotheses
- Increase understanding of the structure and function of social-ecological systems

# MentalModeler v0.2

## Design Goals:

- Represent and standardize stakeholder knowledge and values in resource decision-making
- Provide flexibility and ease in the modeling process
- Create datasets which can **compare** and **combine** stakeholder understanding and values
- Create datasets which can be integrated with expert knowledge, scientific datasets, and used to test co-developed hypotheses
- Increase understanding of the structure and function of social-ecological systems

# MentalModeler v0.2

## Design Goals:

- Represent and standardize stakeholder knowledge and values in resource decision-making
- Provide flexibility and ease in the modeling process
- Create datasets which can compare and combine stakeholder understanding and values
- Create datasets which can be **integrated** with expert knowledge, scientific datasets, and used to **test co-developed hypotheses**
- Increase understanding of the structure and function of social-ecological systems

# MentalModeler v0.2

## Design Goals:

- Represent and standardize stakeholder knowledge and values in resource decision-making
- Provide flexibility and ease in the modeling process
- Create datasets which can compare and combine stakeholder understanding and values
- Create datasets which can be integrated with expert knowledge, scientific datasets, and used to test co-developed hypotheses
- Increase **understanding** of the structure and function of **social-ecological systems**

# Two ways this is intended to be useful:

1. Research context: Understand how the structure and function of individual and group understanding varies reliably with different value orientations, attitudes and behaviors.

2. Planning context: Share, construct, and revise knowledge about a system to promote learning and adaptability among different experts or stakeholders



# Two ways this is intended to be useful:

1. Research context: Understand how the structure and function of individual and group understanding varies reliably with different value orientations, attitudes and behaviors.

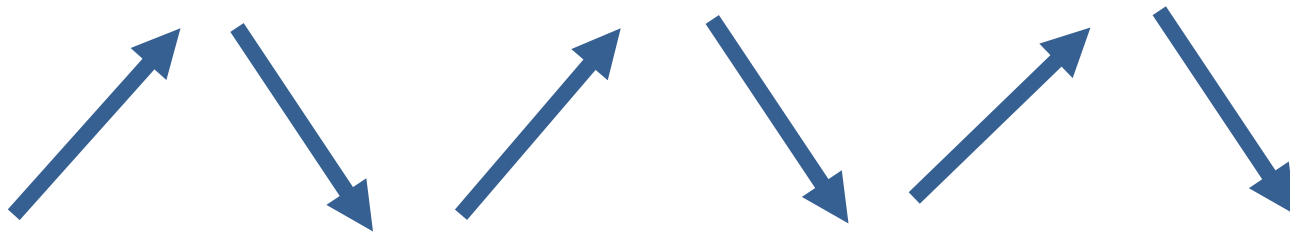

2. Planning context: Share, construct, and revise knowledge about a system to promote learning and adaptability among different experts or stakeholders

# Outline

- **Overview of Fuzzy-logic Cognitive Mapping**
  - Fuzzy Numbers and Fuzzy Sets
  - Cognitive Mapping
  - Doing the calculations the old fashioned way:
    - Structural Metrics
    - Functional Metrics
- **Introduction to *Mental Modeler***
  - *Case study of Collaborative Modeling for Citizen Scientists*
- **New Analytical Capabilities coming soon!**
  - Integrating MMP files into R
- **Building a Model**
  - *How do stakeholders view the relationship between logging, economic development and wildlife habitat?*

# Outline

- **Overview of Fuzzy-logic Cognitive Mapping**
  - Fuzzy Numbers and Fuzzy Sets
  - Cognitive Mapping
  - Doing the calculations the old fashioned way:
    - Structural Metrics
    - Functional Metrics
- **Introduction to *Mental Modeler***
  - *Case study of Collaborative Modeling for Citizen Scientists*
- **New Analytical Capabilities coming soon!**
  - Integrating MMP files into R
- **Building a Model**
  - *How do stakeholders view the relationship between logging, economic development and wildlife habitat?*

What is a FCM?

# Fuzzy-logic Cognitive Mapping

A **Fuzzy cognitive map** is a cognitive map within which the relations between the elements (e.g. concepts, events, project resources) of a "mental landscape" can be used to compute the "strength of impact" of these elements.

Fuzzy cognitive maps are signed fuzzy digraphs.

Spreadsheets or tables are used to map FCMs into matrices for further computation

Reliant on **fuzzy logic** AND cognitive mapping



Bart Kosko  
Professor, USC

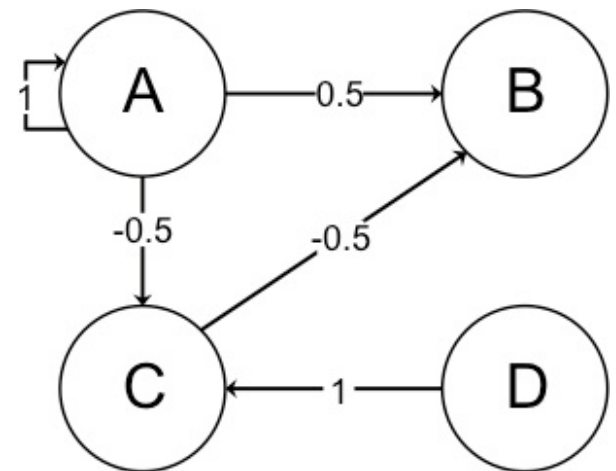

# Fuzzy Set Theory

- *Fuzzy Number*
  - *Number 'x'*
  - *Near 'x'*
  - *Almost 'x'*

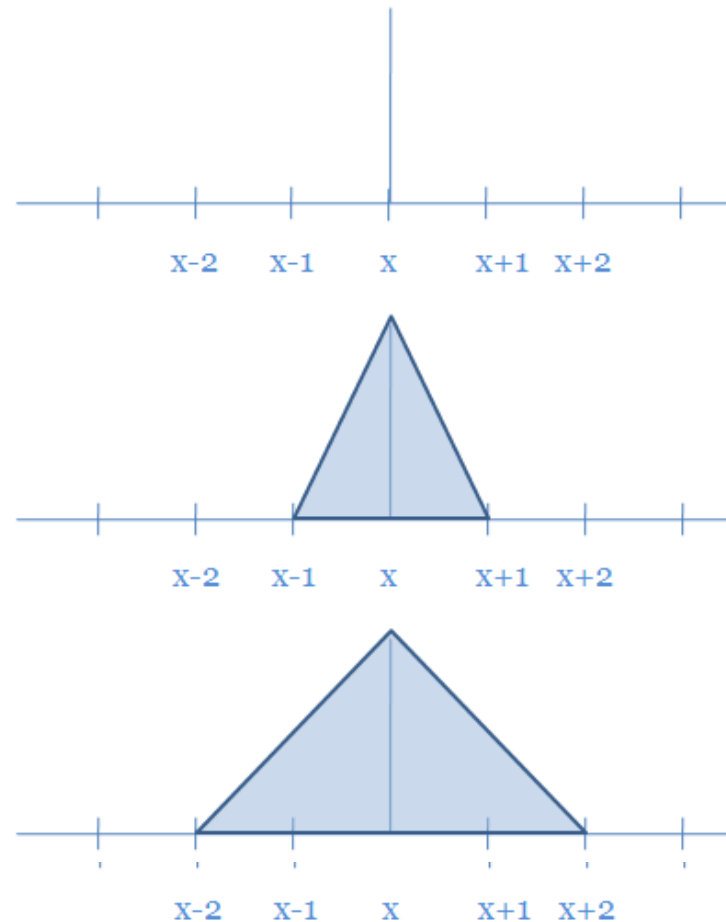

# Fuzzy Set Theory

*A fuzzy set  $A$  in  $U$  may be represented as a set of ordered pairs. Each pair consists of a generic element  $x$  and its grade of membership function; that is*

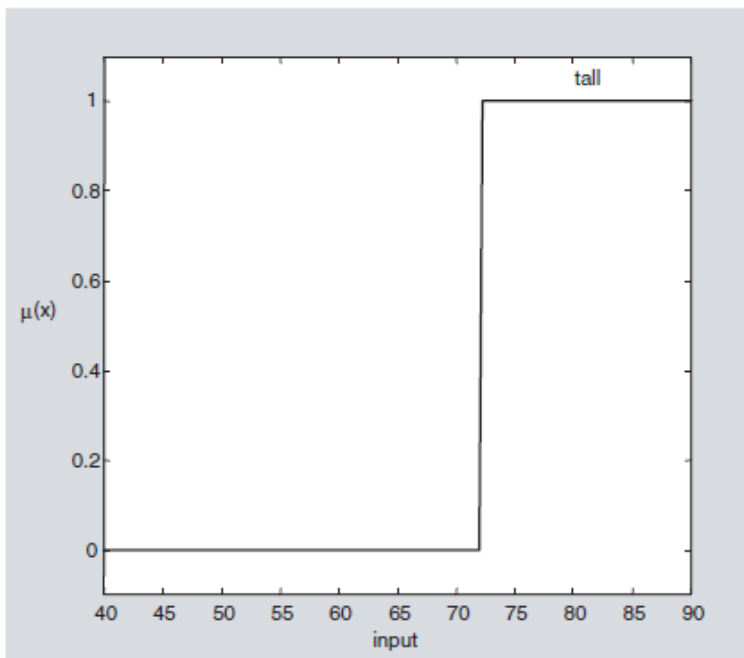

(a) Crisp membership function

# Fuzzy Set Theory

*A fuzzy set  $A$  in  $U$  may be represented as a set of ordered pairs. Each pair consists of a generic element  $x$  and its grade of membership function; that is*

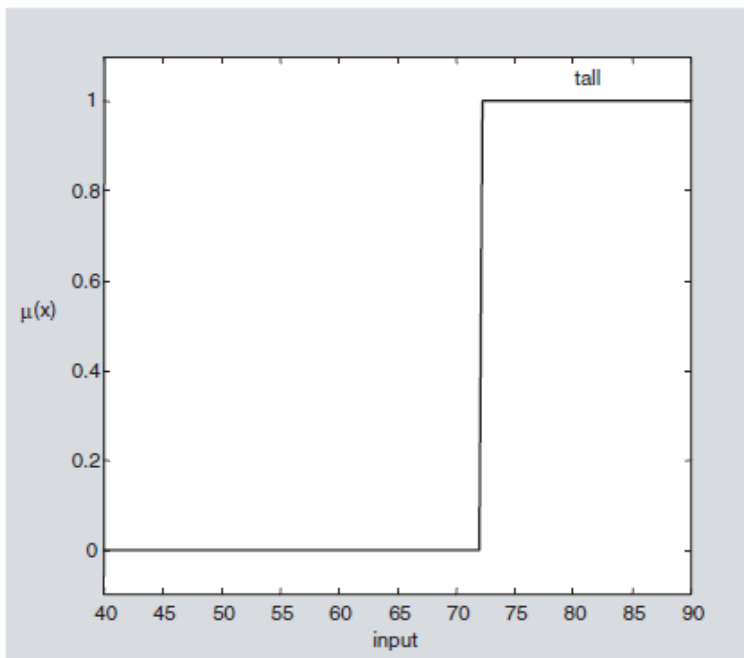

(a) Crisp membership function

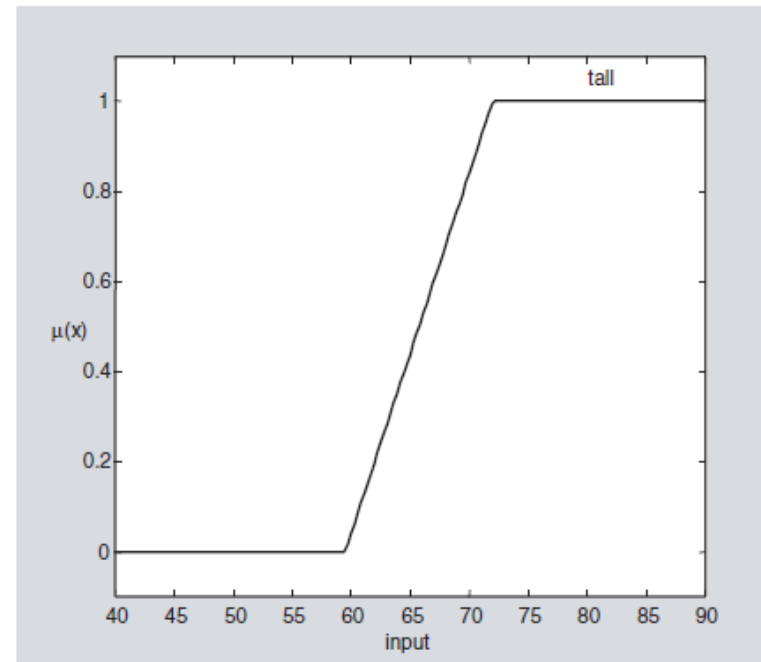

(b) Fuzzy membership function



# Fuzzy Set Theory

- *Fuzzy set operations = OR, AND, NOT*
- *Establishes a rule-based interference system:*

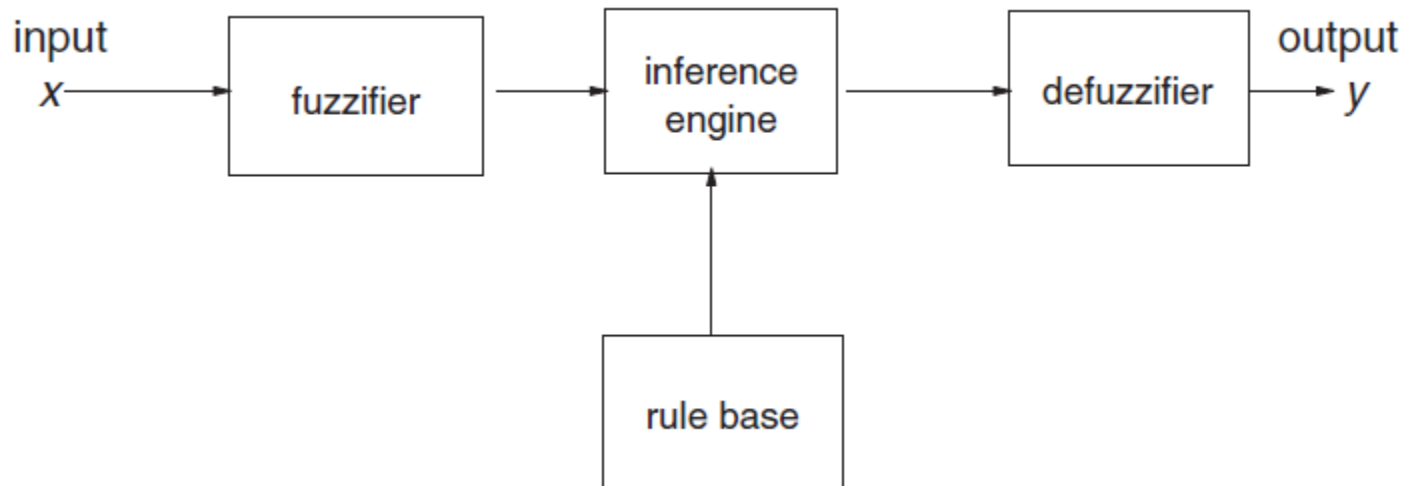

# Fuzzy Set Theory

- *Fuzzy set operations = OR, AND, NOT*
- *Establishes a rule-based interference system:*

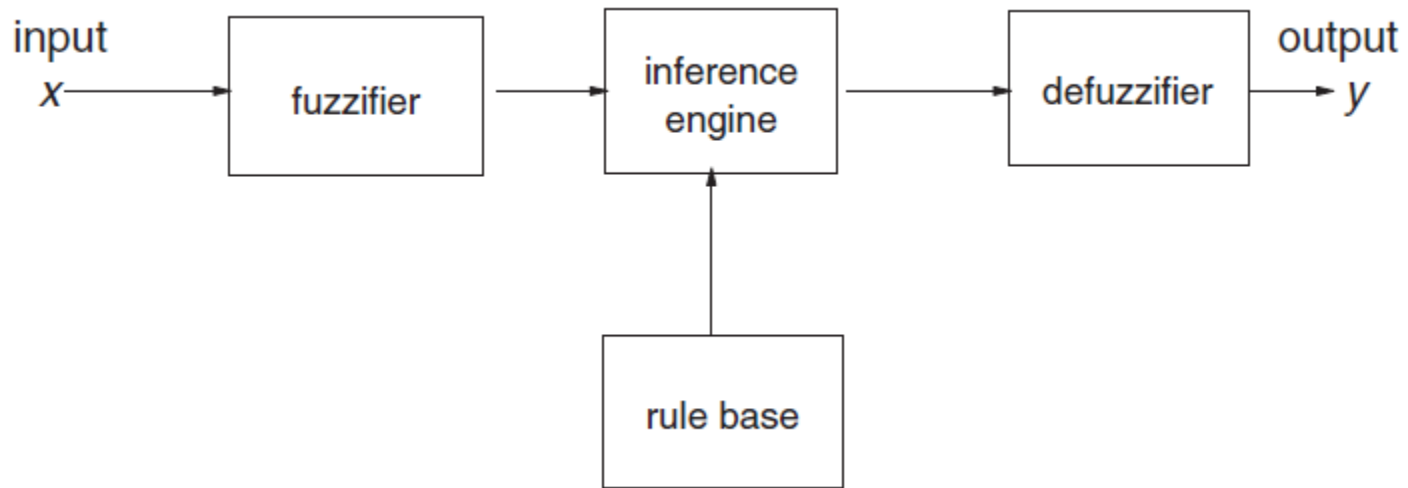

→ **If** apples are green  
**AND** small **THEN** → Not ready to eat

# Fuzzy Set Theory

- *Fuzzy set operations = OR, AND, NOT*
- *Establishes a rule-based interference system:*

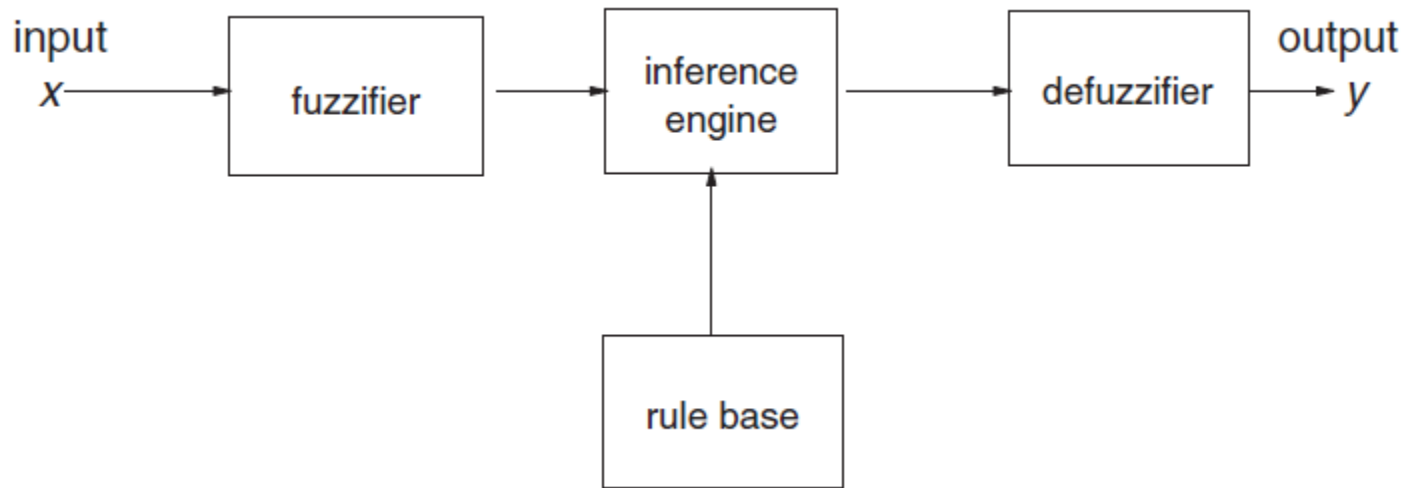

→ **If** apples are red  
**AND** large **THEN** → Ready to eat

# Fuzzy Set Theory

- *Fuzzy set operations = OR, AND, NOT*
- *Establishes a rule-based interference system:*

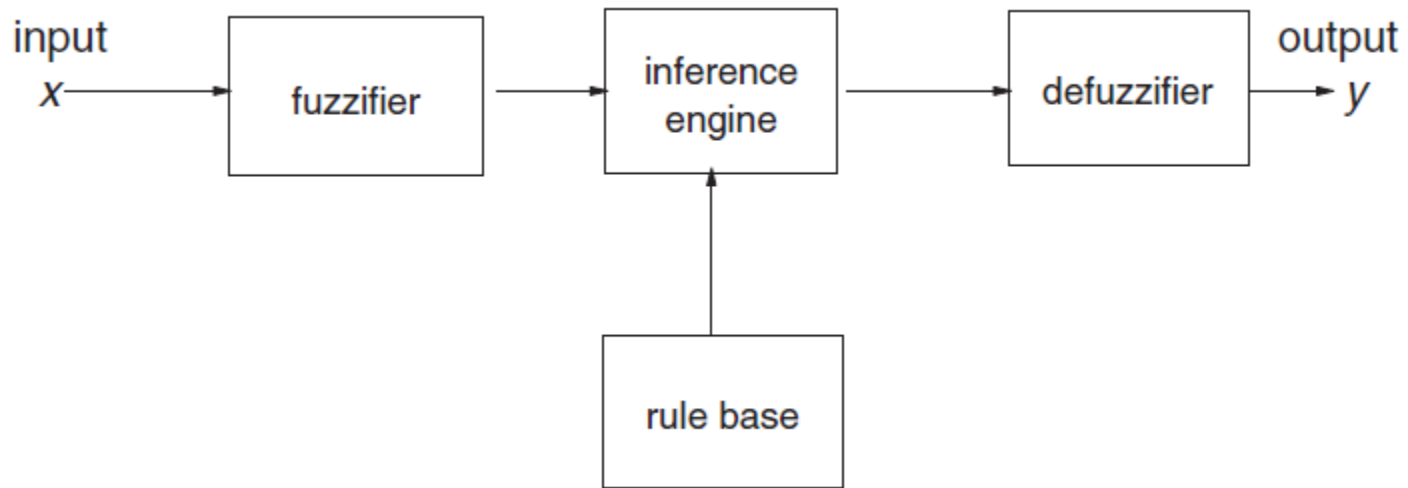

**Apply  
qualitative Rules**



**Make Decisions**

# Fuzzy Set Theory

- *Fuzzy set operations = OR, AND, NOT*
- *Establishes a rule-based inference system:*

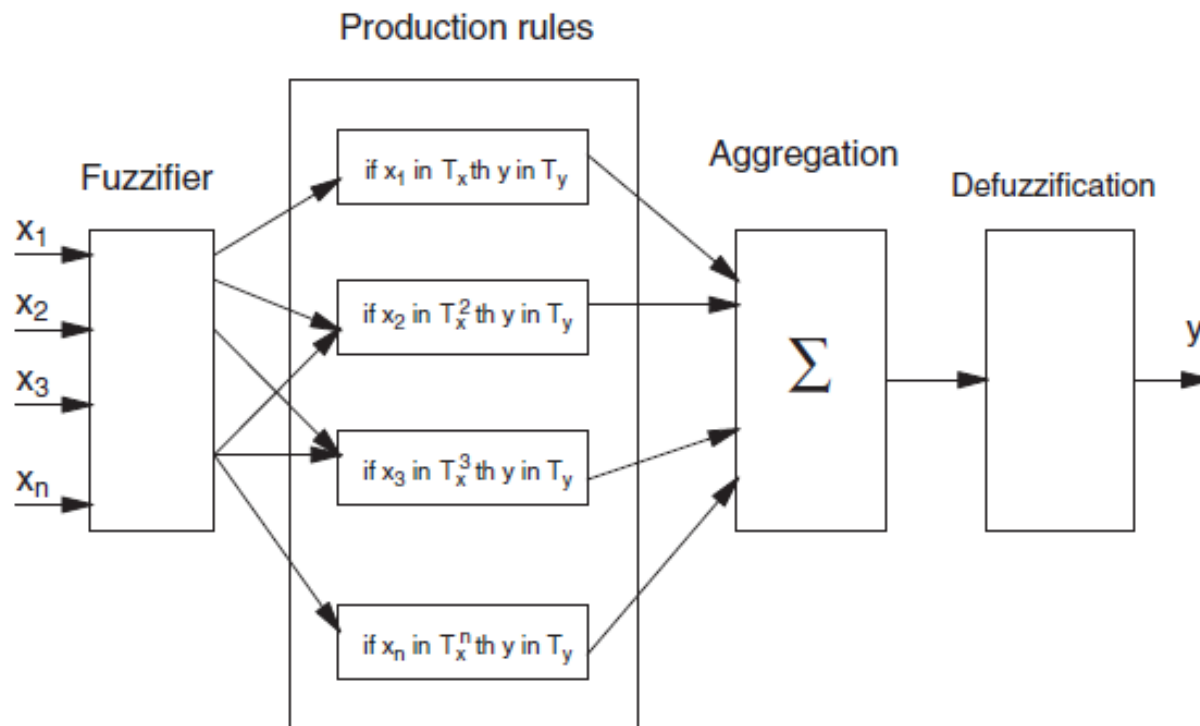

# Fuzzy Set Theory

- *Fuzzy set operations = OR, AND, NOT*
- *Establishes a rule-based inference system:*

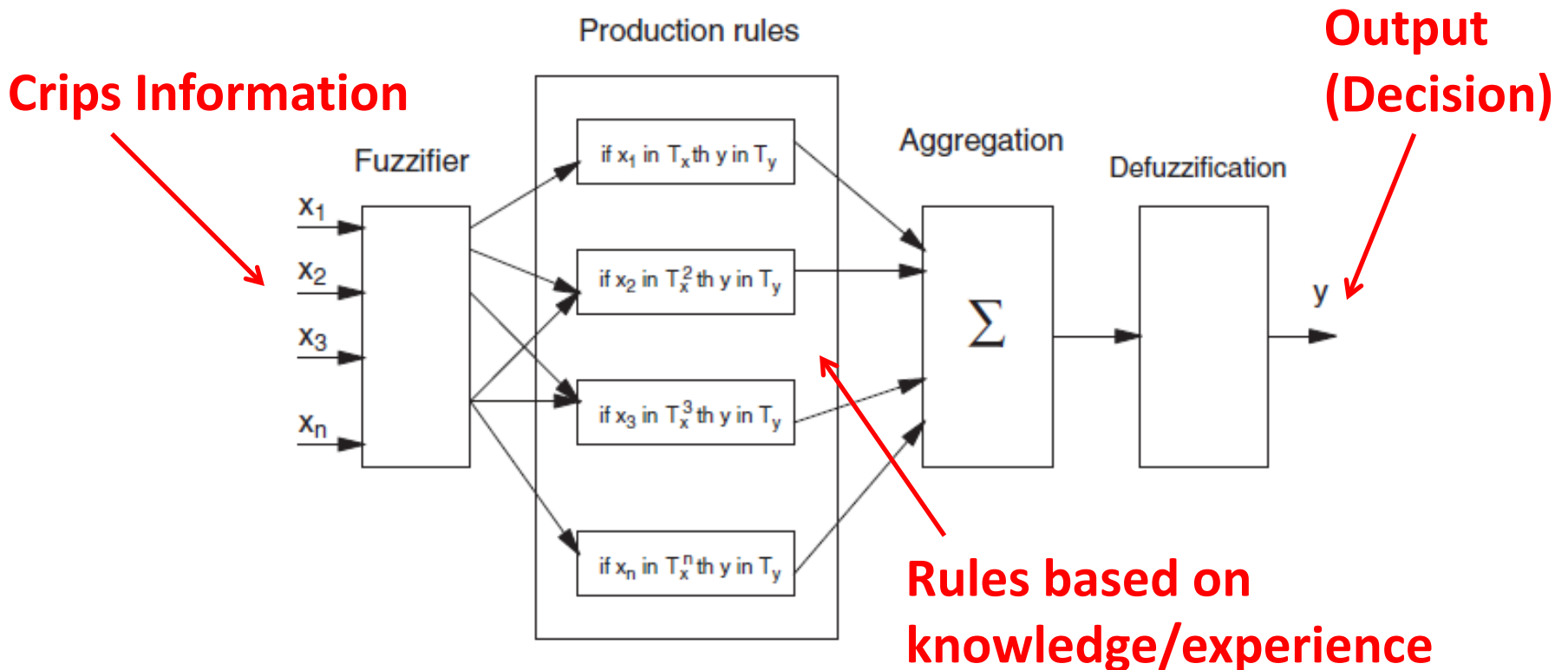

# Fuzzy-logic Cognitive Mapping

A **Fuzzy cognitive map** is a cognitive map within which the relations between the elements (e.g. concepts, events, project resources) of a "mental landscape" can be used to compute the "strength of impact" of these elements.

Fuzzy cognitive maps are signed fuzzy digraphs.

Spreadsheets or tables are used to map FCMs into Matrices for further computation

Reliant on fuzzy logic AND **cognitive mapping**



Bart Kosko  
Professor, USC

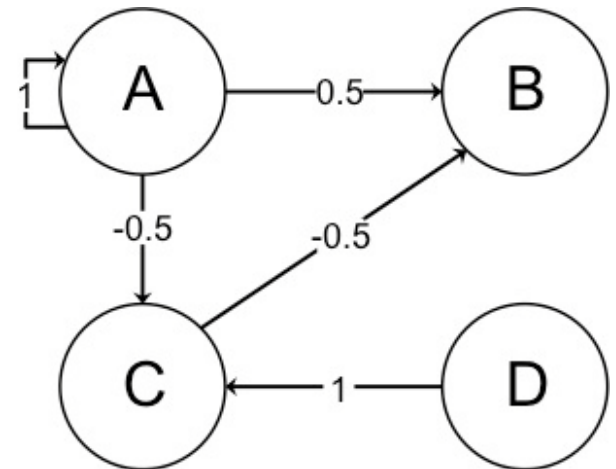

# Concept or Cognitive Mapping?

In 1943 Kenneth Craik wrote *The Nature of Explanation*. In this book he laid the foundation for the concept of **mental models**, that the mind forms models of reality and uses them to predict similar future events





# Concept or Cognitive Mapping?

In 1943 Kenneth Craik wrote *The Nature of Explanation*. In this book he laid the foundation for the concept of **mental models**, that the mind forms models of reality and uses them to predict similar future events

Introduced by Edward Tolman in 1948, **cognitive map** is a type of mental representation which serves an individual to acquire, code, store, recall, and decode information about the relative locations and attributes of phenomena in their everyday or metaphorical **spatial environment**



# Concept or Cognitive Mapping?

In 1943 Kenneth Craik wrote *The Nature of Explanation*. In this book he laid the foundation for the concept of **mental models**, that the mind forms models of reality and uses them to predict similar future events

Introduced by Edward Tolman in 1948, **cognitive map** is a type of mental representation which serves an individual to acquire, code, store, recall, and decode information about the relative locations and attributes of phenomena in their everyday or metaphorical **spatial environment**

Robert Axelrod (1976) was the first to use the term in reference to the content and structure of individuals' minds, thereby shifting its applied meaning from **referring to a map that is cognitive, to a map of cognition** (Doyle and Ford 1999)

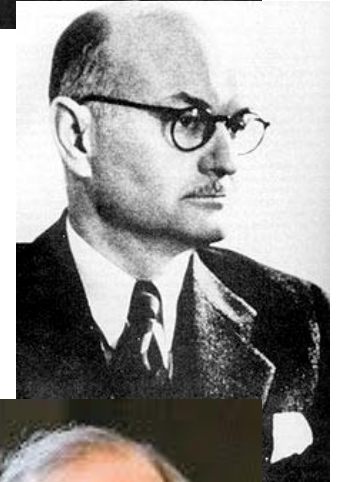

# Concept or Cognitive Mapping?

A **concept map** is a diagram showing the relationships among concepts. **It is a graphical tool for organizing and representing knowledge.**

Concepts, usually represented as boxes or circles, are connected with labeled arrows in a downward-branching hierarchical structure. The relationship between concepts can be articulated in linking phrases such as "gives rise to", "results in", "is required by," or "contributes to"

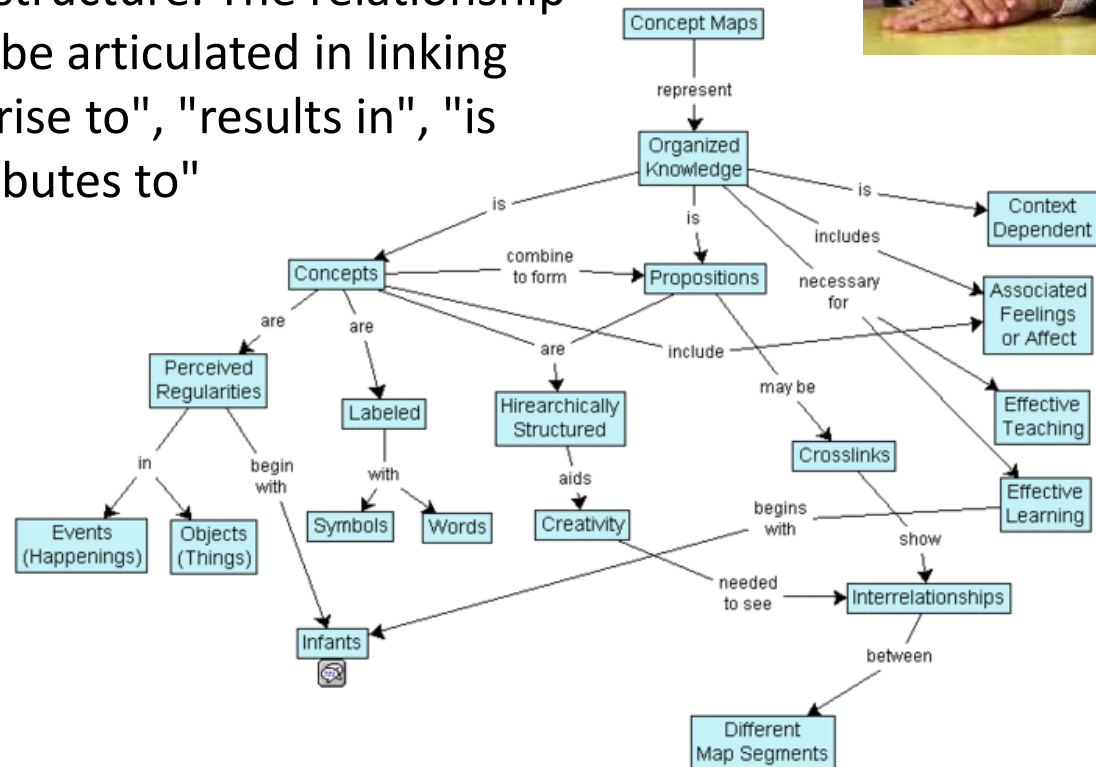

# Brining it all together: Fuzzy-logic Cognitive Mapping (FCM)

Explicit representation  
of an internal mental  
model of relationships  
between concepts  
constructed over time...

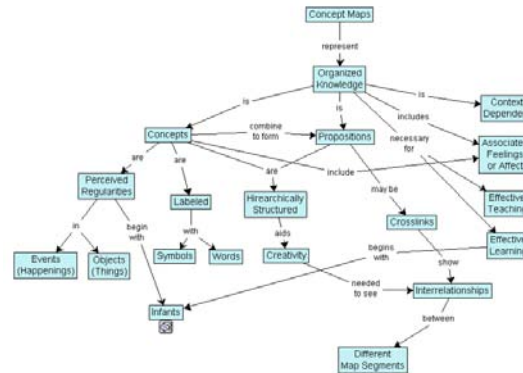

# Brining it all together: Fuzzy-logic Cognitive Mapping (FCM)

Explicit representation  
of an internal mental  
model of relationships  
between concepts  
constructed over time...

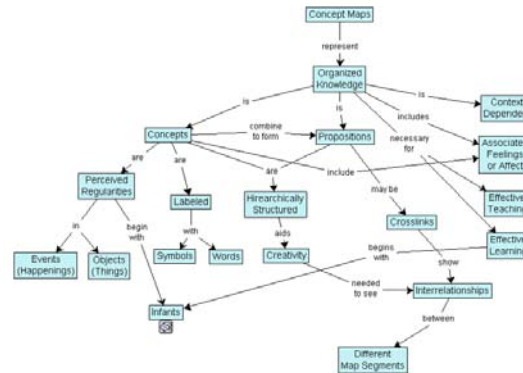

...that applies a set of  
associative rules  
thought to be similar to  
the ways in which  
individuals are able to  
make context  
appropriate decisions

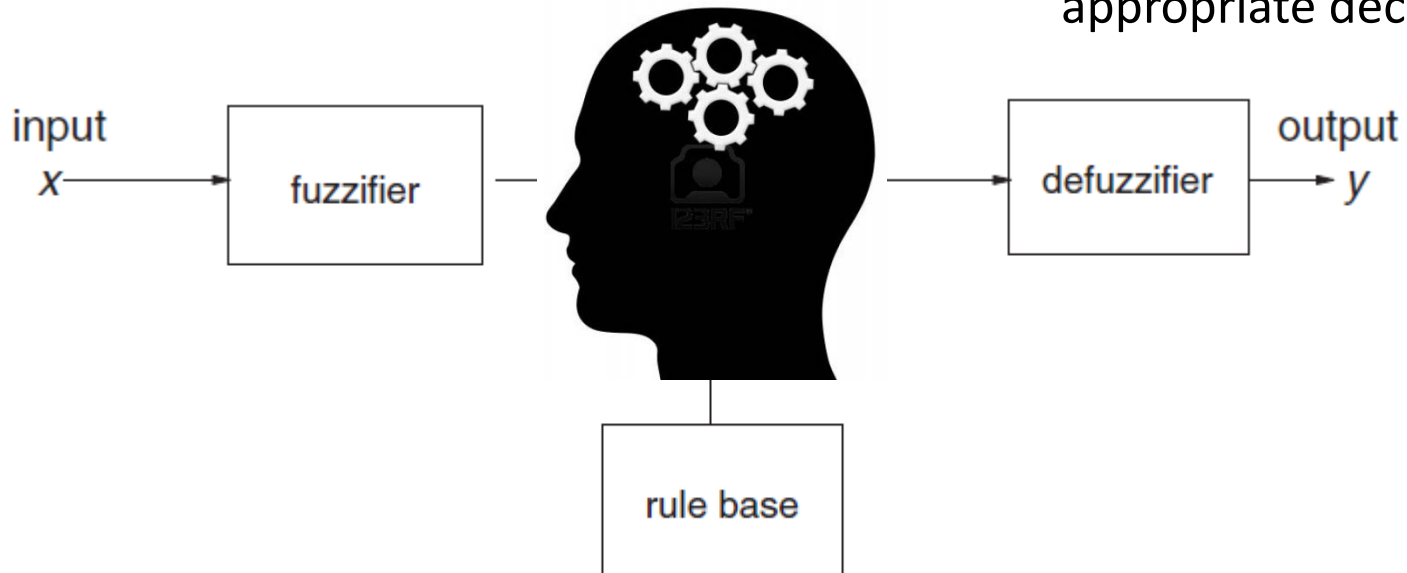

How to construct a FCM?

# Brining it all together:

## Fuzzy-logic Cognitive Mapping (FCM)

- A **Fuzzy cognitive map** is a special kind of cognitive/concept map within which the **components** and **relationships** between the components are **defined in specific ways**.
  - **Components** in a fuzzy-logic cognitive map need to be defined as **things that can go increase or decrease** (like precipitation, animal populations, satisfaction, hunger, or traffic)
  - **Relationships** in an fuzzy-logic cognitive map have 2 main characteristics: (a) **the direction of a relationship** (which way the arrow is pointing) and (b) **the degree of influence one component can have on another** (positively or negatively) parameterized between a fuzzy set from 0 and 1.

# Example

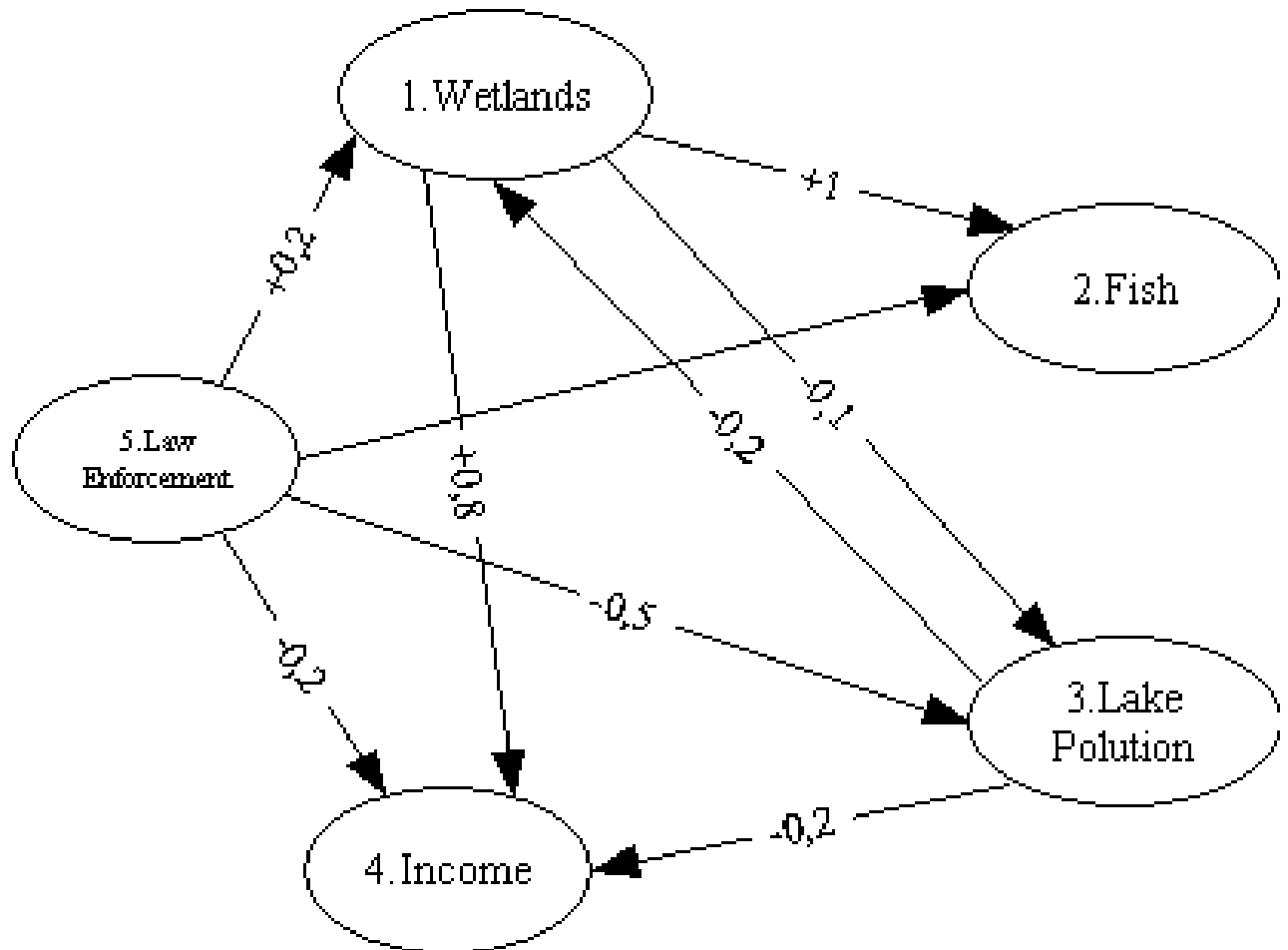



# Example

## Components

The amount of wetland, the amount of law enforcement and income can all go up or down

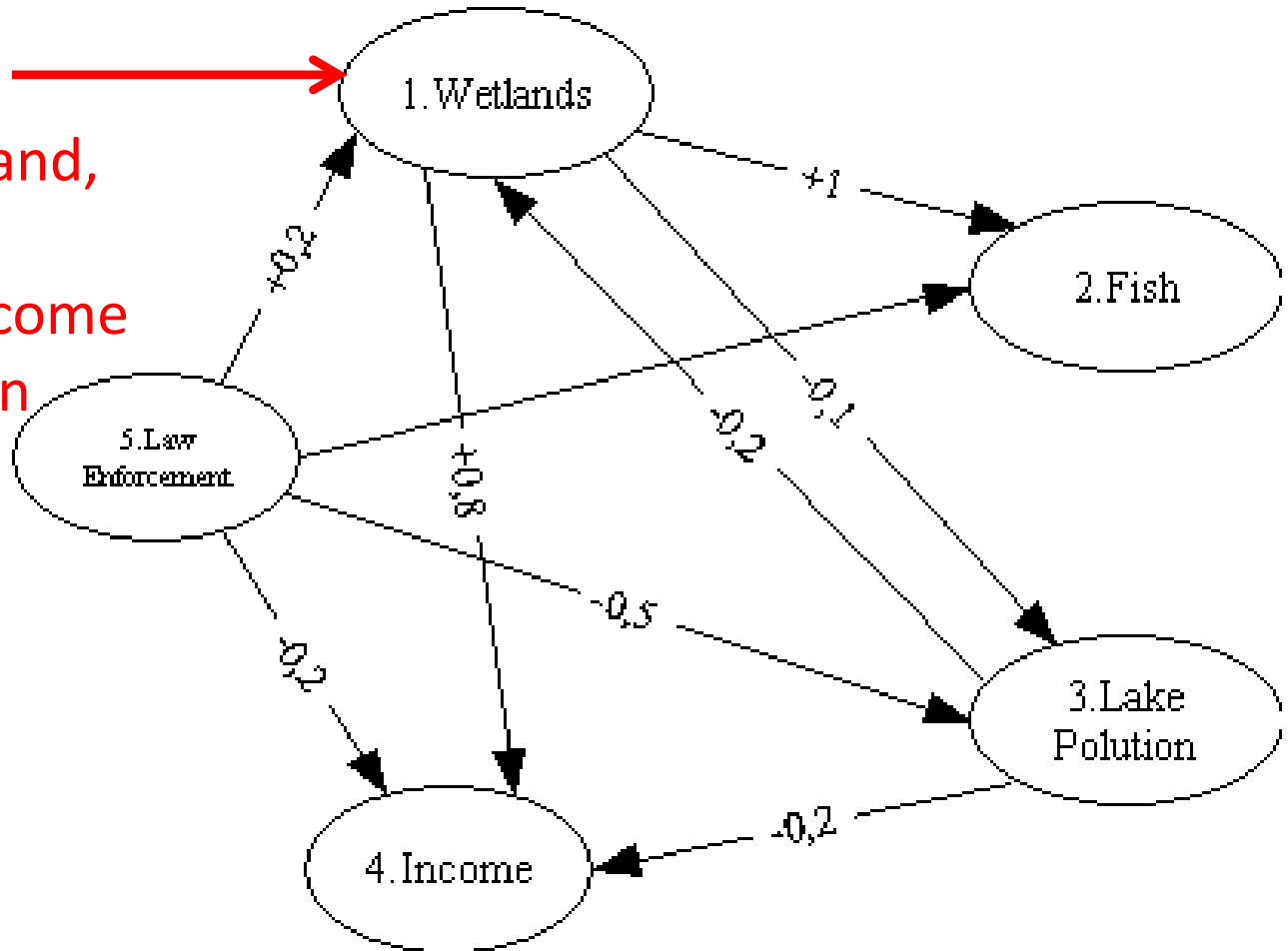

# Example

## Components

The amount of wetland, the amount of law enforcement and income can all go up or down

## Relationships

These direction of the arrows, positive or negative sign and numbers (between +1.0 and -1.0) all indicate the degree of influence one component can have on another

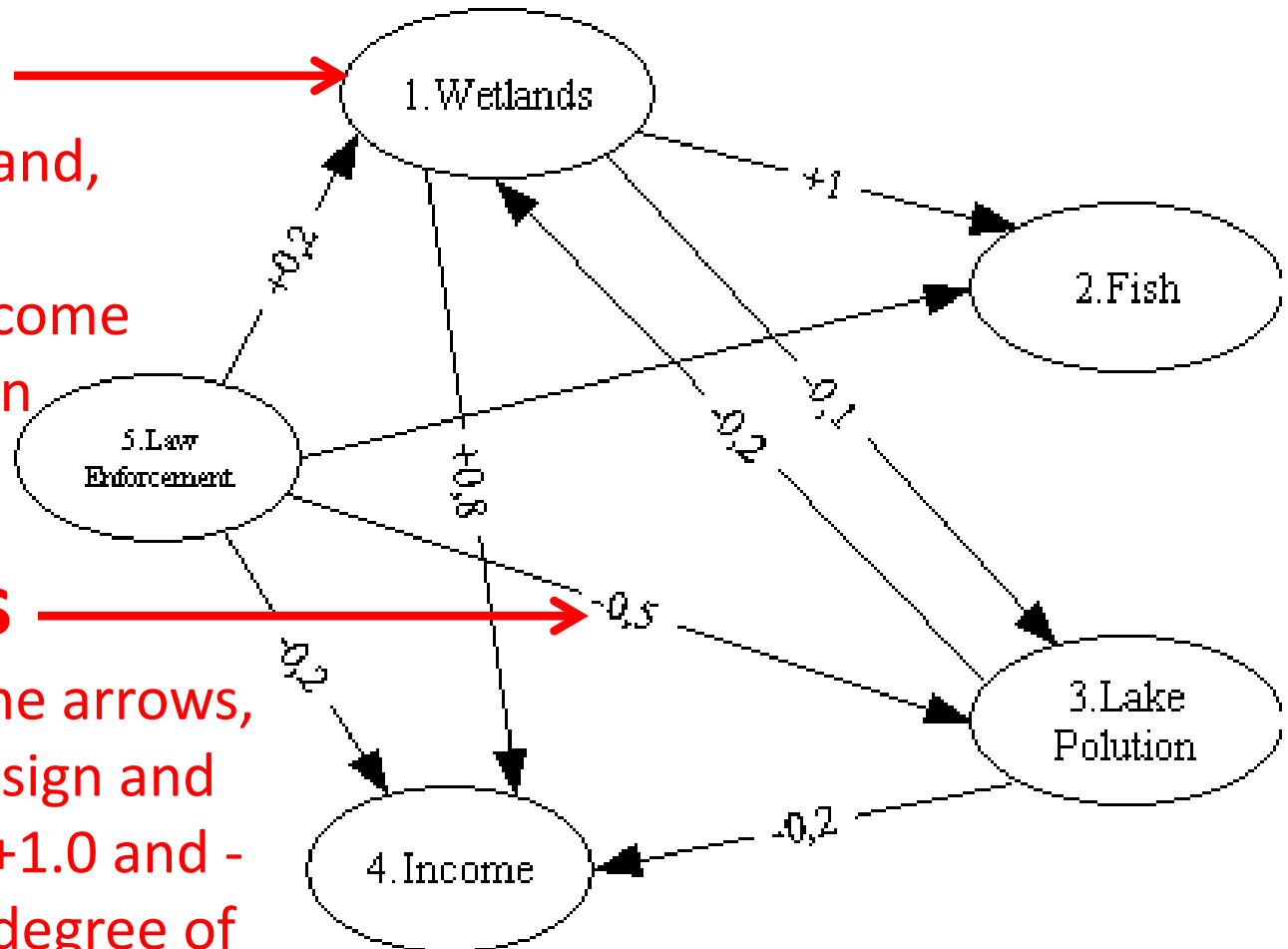

# Thinking about relationships

As the amount of wetlands increases, the number of fish increases a lot (indicated by the +1)

As lake pollution increases, the amount of wetlands decreases slightly (-0.2)

As law enforcement increases, lake pollution decreases a medium amount (+0.5)

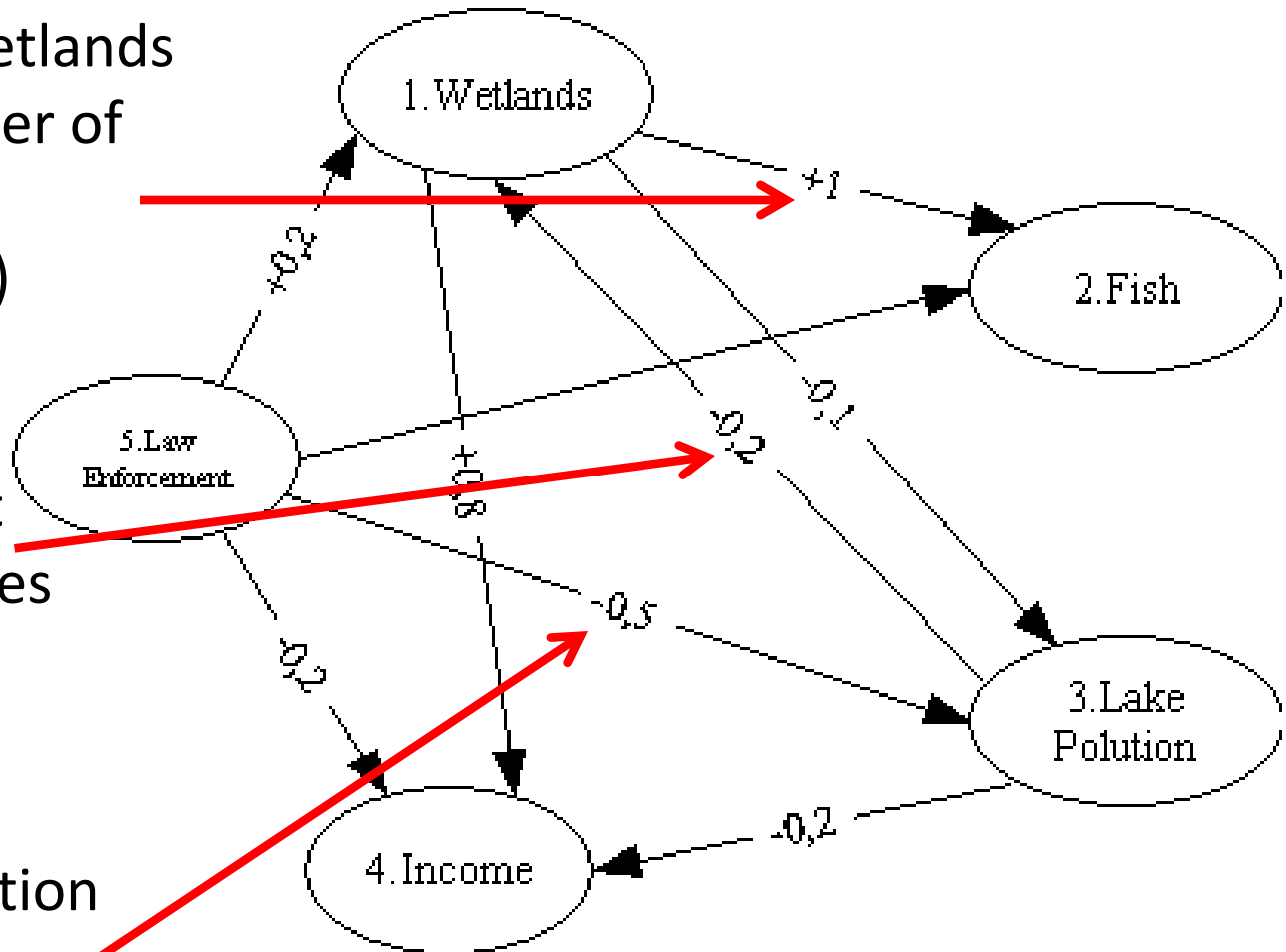

# Thinking about relationships

Remember, the direction of the arrow indicates the direction of increase or decrease. The number value included on the arrow could be anything between +1 (as one component goes up the other component increases a lot) to -1 (as one component goes up the other component decreases a lot)

# Thinking about relationships

Remember, the direction of the arrow indicates the direction of increase or decrease. The number value included on the arrow could be anything between +1 (as one component goes up the other component increases a lot) to -1 (as one component goes up the other component decreases a lot)

These number values on the lines could even be **qualitatively defined** and then later translated into quantitative values:

increases a lot	= +1
increases	= +0.5
increases a little	= +0.25
decreases a little	= -0.25
decreases	= -0.5
decreases a lot	= -1

# Rule of Thumb for Relationships

When determining the relationships between components in an FCM always ask yourself 2 questions:

1. When this component increases, does the other component increase or decrease?
2. Is it a high increase/decrease, medium increase/decrease or low increase/decrease?

How can you analyze an FCM?

# What are they good for?

- Calculating Structural Network Metrics
  - Measuring and representing knowledge (and variation)
  - Determining driving variables and sensitive variables and common belief structures



# What are they good for?

- Calculating Structural Network Metrics
  - Measuring and representing knowledge (and variation)
  - Determining driving variables and sensitive variables and common belief structures
- Calculating Scenario (Functional) Analysis
  - Understanding how stakeholders anticipate the impacts of environmental change
  - Decreasing uncertainty associated with environmental change

# Knowledge Structure

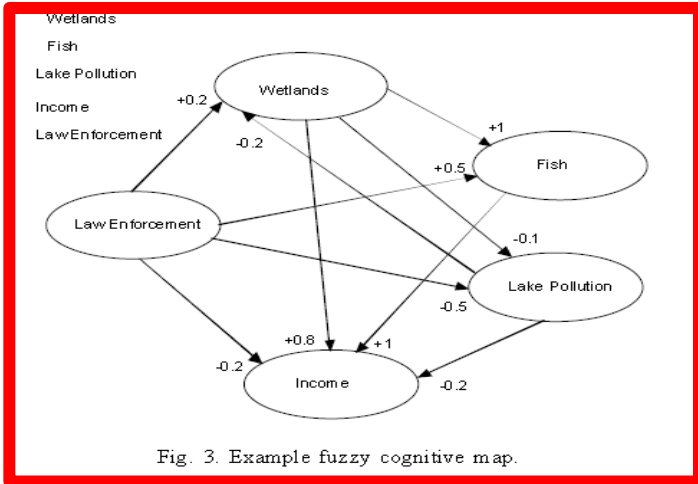

Cognitive Maps collected can then be translated into a matrix format for analyses

	1. Amount of wetland	2. Fish Population	3. Pollution	4. Livelihood	5. Laws
1. Amount of wetland	0	1	-0.1	0.8	0
2. Fish Population	0	0	0	1	0
3. Pollution	-0.2	-1	0	-0.2	0
4. Livelihood	0	0	0	0	0
5. Laws	0.2	0.5	-0.5	-0.2	0

Mental Model Structural Measurement	Description of Measure and Cognitive Inference
N (Concepts)	Number of variables included in model; higher number of concepts indicates more components in the mental model (Özesmi and Özesmi 2004)
N (Connections)	Number of connections included between variables; higher number of connections indicates higher degree of interaction between components in a mental model (Özesmi and Özesmi 2004)
N (Transmitter)	Components which only have “forcing” functions; indicates number of components that effect other system components but are not affected by others (Eden et al.1992)
N (Receiver)	Components which have only receiving functions; indicates the number of components that are affected by other system components but have no effect (Eden et al.1992)
N (Ordinary)	Components with both transmitting and receiving functions; indicates the number of concepts that influence and are influenced by other concepts (Eden et al.1992)



	1.Amount of wetland	2. Fish Population	3. Pollution	4. Livelihood	5. Laws
1. Amount of wetland	0	1	-0.1	0.8	0
2. Fish Population	0	0	0	1	0
3. Pollution	-0.2	-1	0	-0.2	0
4. Livelihood	0	0	0	0	0
5. Laws	0.2	0.5	-0.5	-0.2	0



$$\text{od}(v_i) = \sum_{k=1}^N \bar{a}_{ik}$$

$$\text{id}(v_i) = \sum_{k=1}^N \bar{a}_{ki}$$

Mental Model Structural Measurement	Description of Measure and Cognitive Inference
Centrality	Absolute value of either (a) overall influence in the model (all + and – relationships indicated, for entire model) or (b) influence of individual concepts as indicated by positive (+) or negative (-) values placed on connections between components; indicates (a) the total influence (positive and negative) to be in the system or (b) the conceptual weight/importance of individual concepts (Kosko 1986a). The higher the value, the greater is the importance of all concepts or the individual weight of a concept in the overall model
C/N	Number of connections divided by number of variables (concepts). The lower the C/N score, the higher the degree of connectedness in a system (Özesmi and Özesmi 2004)
Complexity	Ratio of receiver variables to transmitter variables. Indicates the degree of resolution and is a measure of the degree to which outcomes of driving forces are considered. Higher complexity indicates more complex systems thinking (Eden et al.1992; Özesmi and Özesmi 2004)
Density	Number of connections compared to number of all possible connections. The higher the density, the more potential management polices exist (Özesmi and Özesmi 2004; Hage and Harary 1983)
Hierarchy Index	Index developed to indicate hierarchical to democratic view of the system. On a scale of 0-1, indicates the degree of top-down down (score 1) or democratic perception (score 0) of the mental model (McDonald 1983)

$$D = \frac{C}{N(N-1)}$$

$$h = \frac{12}{(N-1)N(N+1)} \sum_i \left[ \frac{\text{od}(v_i) - (\sum \text{od}(v_i))}{N} \right]^2$$

# Comparison of Structures



Stakeholder Group	Harvesters	Pre and Post Harvest	Managers	Scientists	Environmental NGO	Community Map
Maps (N)	9	4	5	6	3	27
Number of Variables	16.2(3.0)	12.8(2.1)	15.4(5.8)	19.2(1.71)	19.7(5.5)	27
Number of Transmitter	6.33(3.08)	2.75(1.71)	5.8(3.27)	6.33(1.75)	7.67(3.51)	6
Number of Receiver	1.44(0.88)	2(1.41)	0.8(0.45)	2.33(1.87)	1.67(0.58)	1
Number of Ordinary	8.55(3.16)	8(3.47)	8.8(3.90)	10.33(3.72)	10.67(4.50)	20
Number of Connections	26.22(7.70)	22.5(13.80)	25(13.80)	27.33(7.60)	40.67(19.00)	117
C/N	1.65(0.30)	1.66(1.24)	1.42(0.23)	1.41(0.30)	2.56(1.02)	4.34
Complexity (R:D)	0.34(0.40)	0.38(0.49)	0.27(0.22)	0.50(0.58)	0.17(0.29)	0.17
Density	0.11(0.02)	0.14(0.01)	0.11(0.04)	0.09(0.02)	0.12(0.08)	0.17

Values in Mean (SD)

Gray, S., Chan, A., Clark, D., and R.C. Jordan. 2012 Modeling the integration of stakeholder knowledge in social-ecological system decision-making: Benefits and limitations to knowledge diversity. *Ecological Modeling* 229, 88-96.

# Comparison of Structures



Stakeholder Group	Harvesters	Pre and Post Harvest	Managers	Scientists	Environmental NGO	Community Map
Maps (N)	9	4	5	6	3	27
Number of Variables	16.2(3.0)	12.8(2.1)	15.4(5.8)	19.2(1.71)	19.7(5.5)	27
Number of Transmitter	6.33(3.08)	2.75(1.71)	5.8(3.27)	6.33(1.75)	7.67(3.51)	6
Number of Receiver	1.44(0.88)	2(1.41)	0.8(0.45)	2.33(1.87)	1.67(0.58)	1
Number of Ordinary	8.55(3.16)	8(3.47)	8.8(3.90)	10.33(3.72)	10.67(4.50)	20
Number of Connections	26.22(7.70)	22.5(13.80)	25(13.80)	27.33(7.60)	40.67(19.00)	117
C/N	1.65(0.30)	1.66(1.24)	1.42(0.23)	1.41(0.30)	2.56(1.02)	4.34
Complexity (R:D)	0.34(0.40)	0.38(0.49)	0.27(0.22)	0.50(0.58)	0.17(0.29)	0.17
Density	0.11(0.02)	0.14(0.01)	0.11(0.04)	0.09(0.02)	0.12(0.08)	0.17

Values in Mean (SD)

Number of components and type of components

# Comparison of Structures



Stakeholder Group	Harvesters	Pre and Post Harvest	Managers	Scientists	Environmental NGO	Community Map
Maps (N)	9	4	5	6	3	27
Number of Variables	16.2(3.0)	12.8(2.1)	15.4(5.8)	19.2(1.71)	19.7(5.5)	27
Number of Transmitter	6.33(3.08)	2.75(1.71)	5.8(3.27)	6.33(1.75)	7.67(3.51)	6
Number of Receiver	1.44(0.88)	2(1.41)	0.8(0.45)	2.33(1.87)	1.67(0.58)	1
Number of Ordinary	8.55(3.16)	8(3.47)	8.8(3.90)	10.33(3.72)	10.67(4.50)	20
Number of Connections	26.22(7.70)	22.5(13.80)	25(13.80)	27.33(7.60)	40.67(19.00)	117
C/N	1.65(0.30)	1.66(1.24)	1.42(0.23)	1.41(0.30)	2.56(1.02)	4.34
Complexity (R:D)	0.34(0.40)	0.38(0.49)	0.27(0.22)	0.50(0.58)	0.17(0.29)	0.17
Density	0.11(0.02)	0.14(0.01)	0.11(0.04)	0.09(0.02)	0.12(0.08)	0.17

Values in Mean (SD)

Complexity is a measure of the amt of Receiver to Driver components and indicates the degree of resolution in the model

# Comparison of Structures



Stakeholder Group	Harvesters	Pre and Post Harvest	Managers	Scientists	Environmental NGO	Community Map
Maps (N)	9	4	5	6	3	27
Number of Variables	16.2(3.0)	12.8(2.1)	15.4(5.8)	19.2(1.71)	19.7(5.5)	27
Number of Transmitter	6.33(3.08)	2.75(1.71)	5.8(3.27)	6.33(1.75)	7.67(3.51)	6
Number of Receiver	1.44(0.88)	2(1.41)	0.8(0.45)	2.33(1.87)	1.67(0.58)	1
Number of Ordinary	8.55(3.16)	8(3.47)	8.8(3.90)	10.33(3.72)	10.67(4.50)	20
Number of Connections	26.22(7.70)	22.5(13.80)	25(13.80)	27.33(7.60)	40.67(19.00)	117
C/N	1.65(0.30)	1.66(1.24)	1.42(0.23)	1.41(0.30)	2.56(1.02)	4.34
Complexity (R:D)	0.34(0.40)	0.38(0.49)	0.27(0.22)	0.50(0.58)	0.17(0.29)	0.17
Density	0.11(0.02)	0.14(0.01)	0.11(0.04)	0.09(0.02)	0.12(0.08)	0.17

Values in Mean (SD)

Density is a measure of potential change within the system



# Comparison of Structures



Stakeholder Group	Harvesters	Pre and Post Harvest	Managers	Scientists	Environmental NGO	Community Map
Maps (N)	9	4	5	6	3	27
Number of Variables	16.2(3.0)	12.8(2.1)	15.4(5.8)	19.2(1.71)	19.7(5.5)	27
Number of Transmitter	6.33(3.08)	2.75(1.71)	5.8(3.27)	6.33(1.75)	7.67(3.51)	6
Number of Receiver	1.44(0.88)	2(1.41)	0.8(0.45)	2.33(1.87)	1.67(0.58)	1
Number of Ordinary	8.55(3.16)	8(3.47)	8.8(3.90)	10.33(3.72)	10.67(4.50)	20
Number of Connections	26.22(7.70)	22.5(13.80)	25(13.80)	27.33(7.60)	40.67(19.00)	117
C/N	1.65(0.30)	1.66(1.24)	1.42(0.23)	1.41(0.30)	2.56(1.02)	4.34
Complexity (R:D)	0.34(0.40)	0.38(0.49)	0.27(0.22)	0.50(0.58)	0.17(0.29)	0.17
Density	0.11(0.02)	0.14(0.01)	0.11(0.04)	0.09(0.02)	0.12(0.08)	0.17

Values in Mean (SD)

Scientists see the more components in the system, more complexity in the system, but less amount of room for change

# Knowledge Function

	1.Amount of wetland	2. Fish Population	3. Pollution	4. Livelihood	5. Laws
1. Amount of wetland	0	1	-0.1	0.8	0
2. Fish Population	0	0	0	1	0
3. Pollution	-0.2	-1	0	-0.2	0
4. Livelihood	0	0	0	0	0
5. Laws	0.2	0.5	-0.5	-0.2	0

$\times [1,1,1,1,1,....]$

Scenario State

- -- Steady State

Relative Change

Components in the FCM can be increased or decreased to understand how the system would react under a range of policy, social, or environmental changes (Kosko 1986)

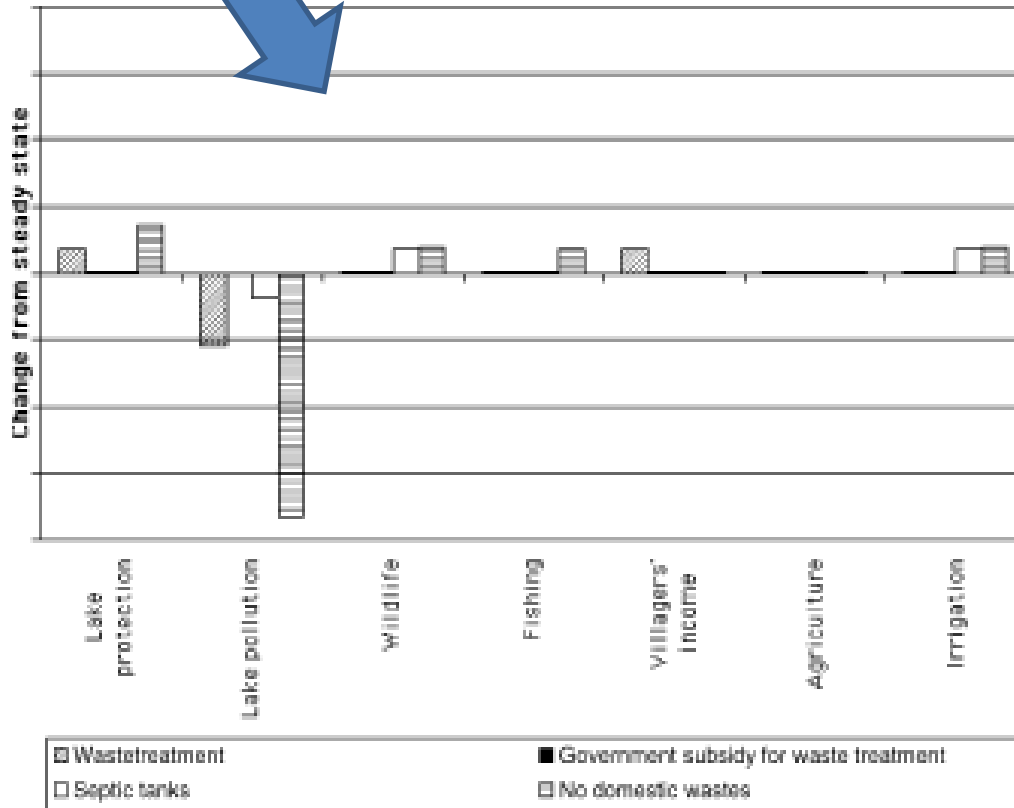

# Comparison of Function

## Scenario: Increase Summer Flounder Population

Increase in **recreational** and commercial fishing, coastal community, fishing pressure and reproduction/spawn

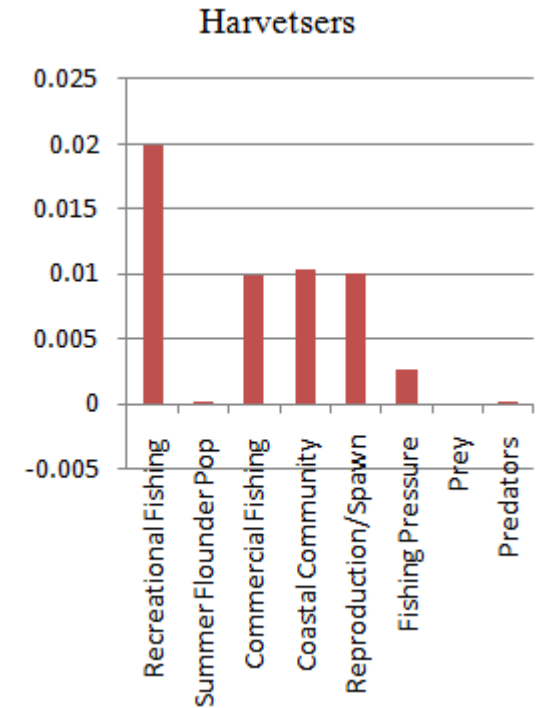

# Comparison of Function

## Scenario: Increase Summer Flounder Population



Increase in **recreational** and commercial fishing, coastal community, fishing pressure and reproduction/spawn

Increase in recreational and commercial fishing, and **coastal community**

Pre and Post Harvest Sectors

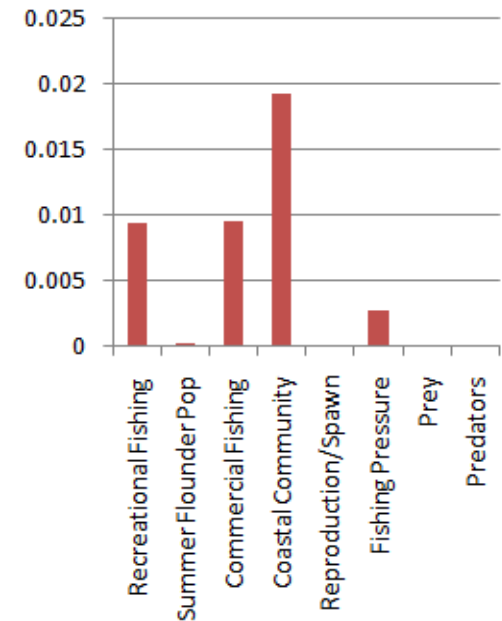

# Comparison of Function

## Scenario: Increase Summer Flounder Population



Increase in **recreational** and commercial fishing coastal community, fishing pressure and reproduction/spawn

Increase in recreational and commercial fishing, and **coastal community**

Increase in **recreational** fishing, coastal community, reproduction/spawn, and fishing pressure

Managers

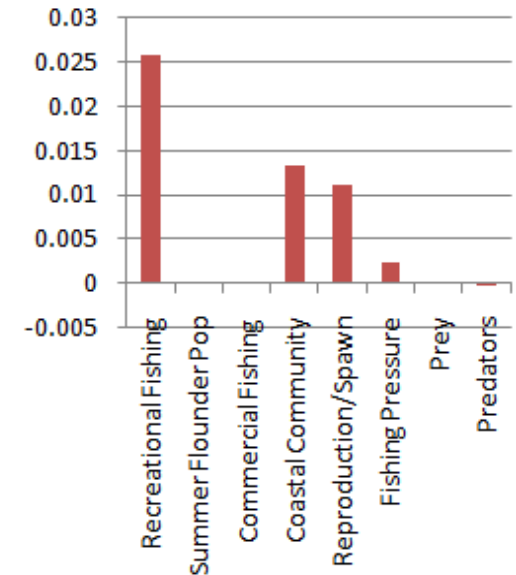

# Comparison of Function

## Scenario: Increase Summer Flounder Population



Increase in **recreational** and commercial fishing, coastal community, fishing pressure and reproduction/spawn



Increase in recreational and commercial fishing, and **coastal community**



Increase in **recreational** fishing, coastal community, reproduction/spawn, and fishing pressure



Increase in **reproduction/spawn**, fishing pressure, and predators, and Decrease in **prey**

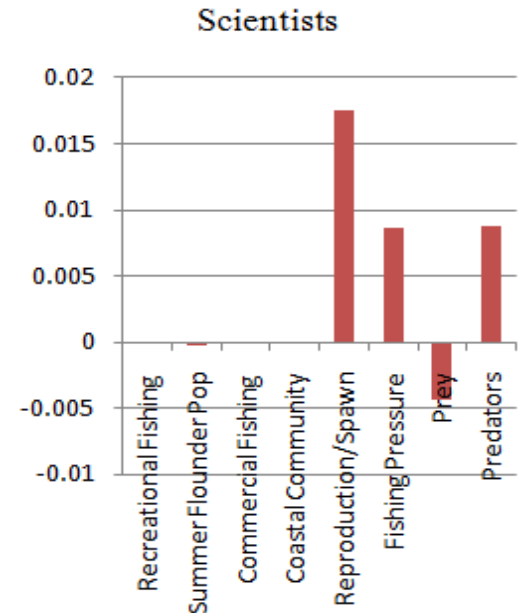

# Comparison of Function

## Scenario: Increase Summer Flounder Population



Increase in **recreational** and commercial fishing, coastal community, fishing pressure and reproduction/spawn



Increase in recreational and commercial fishing, and **coastal community**



Increase in **recreational** fishing, coastal community, reproduction/spawn, and fishing pressure



Increase in **reproduction/spawn**, fishing pressure, and predators, and Decrease in **prey**



Increase in **summer flounder population** and Decrease in **fishing pressure**

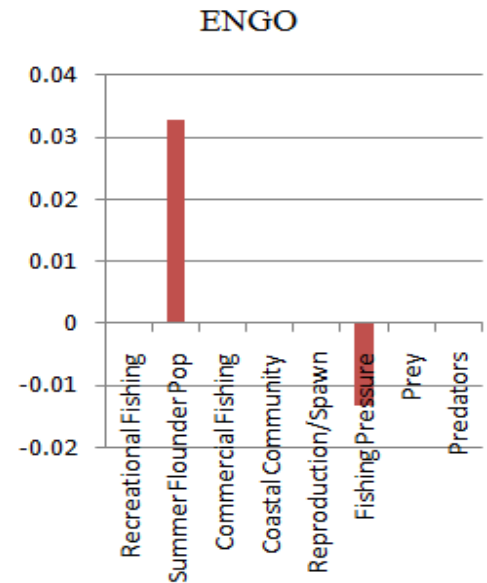

# Outline



- **Overview of Fuzzy-logic Cognitive Mapping**
  - Fuzzy Numbers and Fuzzy Sets
  - Cognitive Mapping
  - Doing the calculations the old fashioned way:
    - Structural Metrics
    - Functional Metrics
- **Introduction to *Mental Modeler***
  - *Case study of Collaborative Modeling for Citizen Scientists*
- **New Analytical Capabilities coming soon!**
  - Integrating MMP files into R
- **Building a Model**
  - *How do stakeholders view the relationship between logging, economic development and wildlife habitat?*



# Outline



- **Overview of Fuzzy-logic Cognitive Mapping**
  - Fuzzy Numbers and Fuzzy Sets
  - Cognitive Mapping
  - Doing the calculations the old fashioned way:
    - Structural Metrics
    - Functional Metrics
- **Introduction to *Mental Modeler***
  - *Case study of Collaborative Modeling for Citizen Scientists*
- **New Analytical Capabilities coming soon!**
  - Integrating MMP files into R
- **Building a Model**
  - *How do stakeholders view the relationship between logging, economic development and wildlife habitat?*

# Case Study: Collaborative land management in Virginia



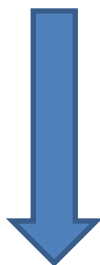

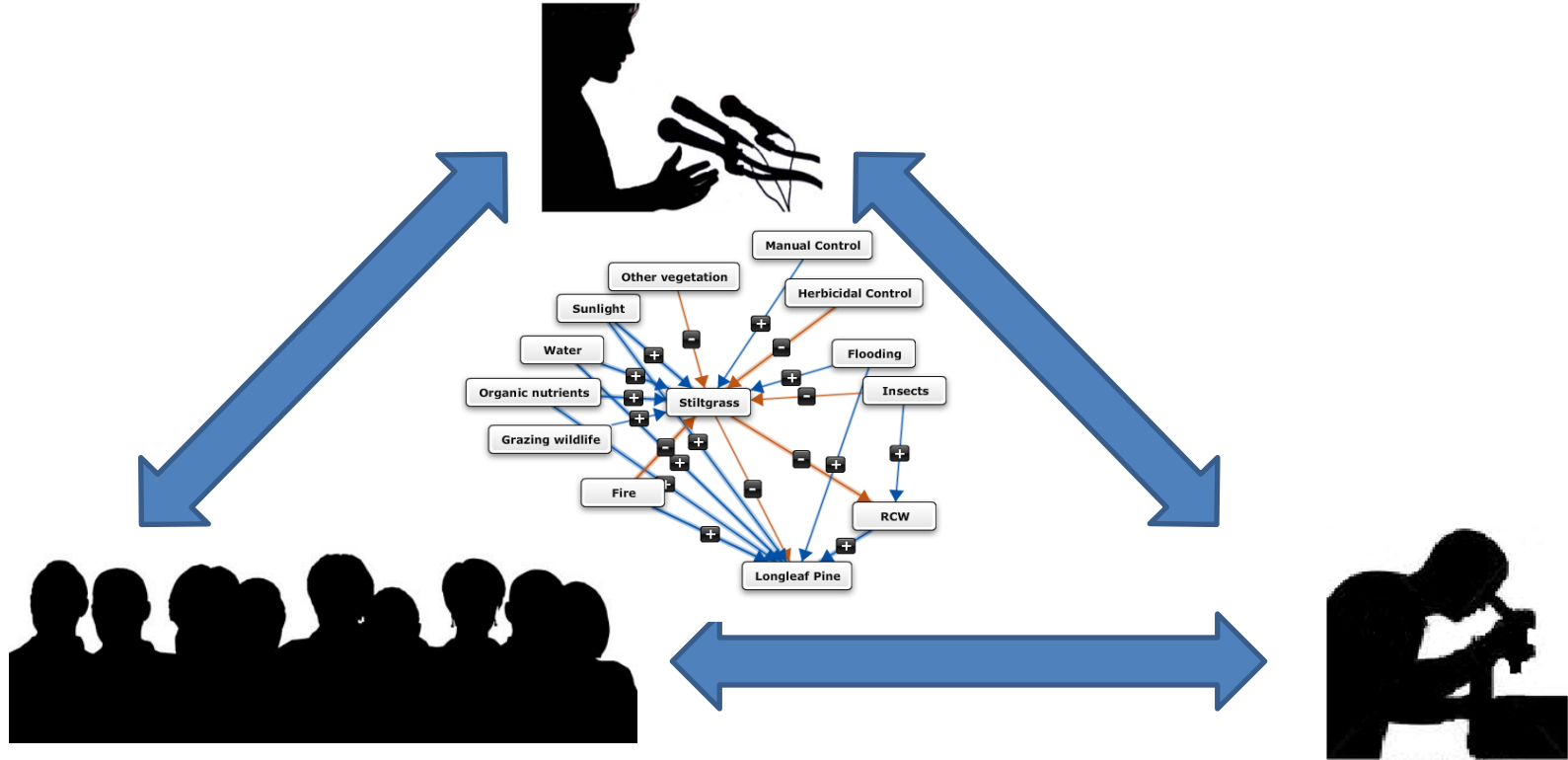

[www.collaborativescience.org](http://www.collaborativescience.org)

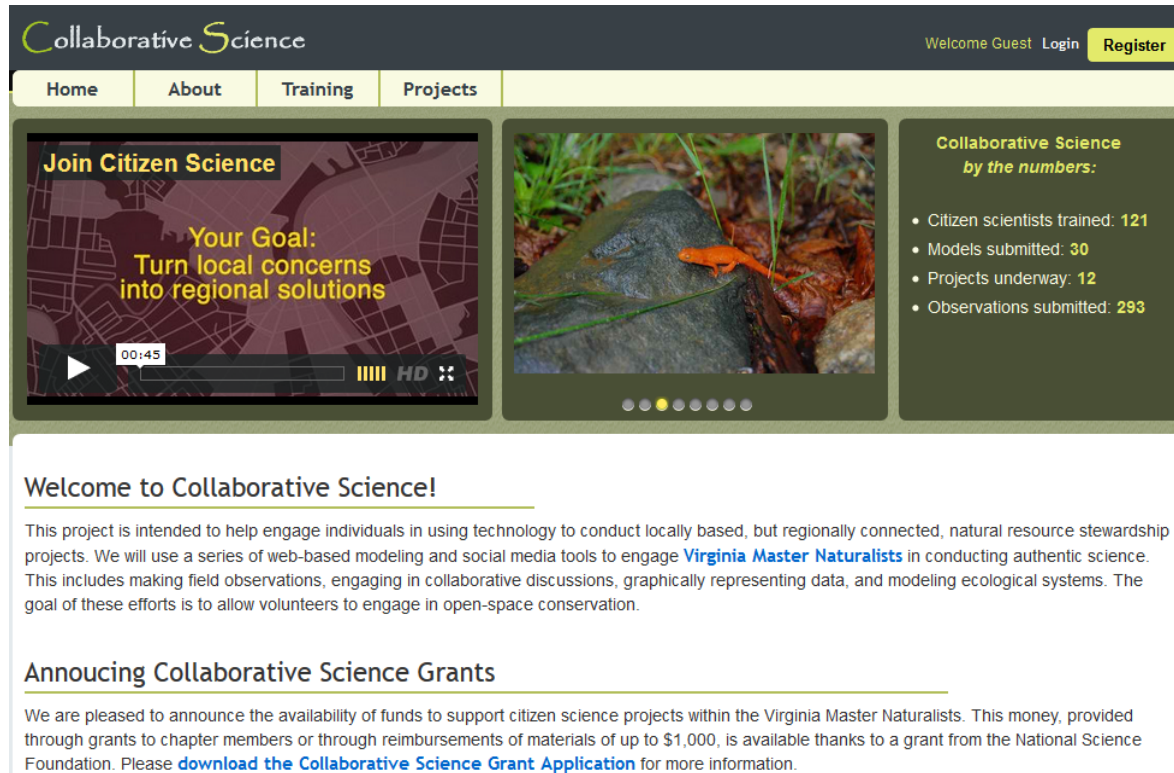

The screenshot shows the homepage of Collaborative Science. At the top, the logo "Collaborative Science" is on the left, and "Welcome Guest Login Register" is on the right. Below the logo is a navigation menu with "Home", "About", "Training", and "Projects". The main content area features a video player on the left with the text "Join Citizen Science" and "Your Goal: Turn local concerns into regional solutions". To the right of the video is a photograph of an orange salamander on a rock. Further right is a statistics section titled "Collaborative Science by the numbers:" with a bulleted list: "Citizen scientists trained: 121", "Models submitted: 30", "Projects underway: 12", and "Observations submitted: 293". Below the main content area are two sections: "Welcome to Collaborative Science!" and "Announcing Collaborative Science Grants", each with a short paragraph of text.

**Collaborative Science**

Welcome Guest Login **Register**

Home About Training Projects

**Join Citizen Science**

Your Goal:  
Turn local concerns  
into regional solutions

00:45

Collaborative Science  
by the numbers:

- Citizen scientists trained: **121**
- Models submitted: **30**
- Projects underway: **12**
- Observations submitted: **293**

**Welcome to Collaborative Science!**

This project is intended to help engage individuals in using technology to conduct locally based, but regionally connected, natural resource stewardship projects. We will use a series of web-based modeling and social media tools to engage **Virginia Master Naturalists** in conducting authentic science. This includes making field observations, engaging in collaborative discussions, graphically representing data, and modeling ecological systems. The goal of these efforts is to allow volunteers to engage in open-space conservation.

**Announcing Collaborative Science Grants**

We are pleased to announce the availability of funds to support citizen science projects within the Virginia Master Naturalists. This money, provided through grants to chapter members or through reimbursements of materials of up to \$1,000, is available thanks to a grant from the National Science Foundation. Please [download the Collaborative Science Grant Application](#) for more information.

<http://collaborativescience.org/cwis438/websites/CyberLearning/Home.php?WebSiteID=16>

# Stream Protection

A local chapter of Virginia Master Naturalists volunteers interested in local land issues and developing an evidence-based management plan

Private land owners lease their land to farmers

Farmers who want to increase grazing capacity and economic benefits from cattle production

State agencies and land owners are concerned about water quality





# Stream Protection

A local chapter of Virginia Master Naturalists volunteers interested in local land issues and developing an evidence-based management plan

Private land owners lease their land to farmers

Farmers who want to increase grazing capacity and economic benefits from cattle production

State agencies and land owners are concerned about water quality

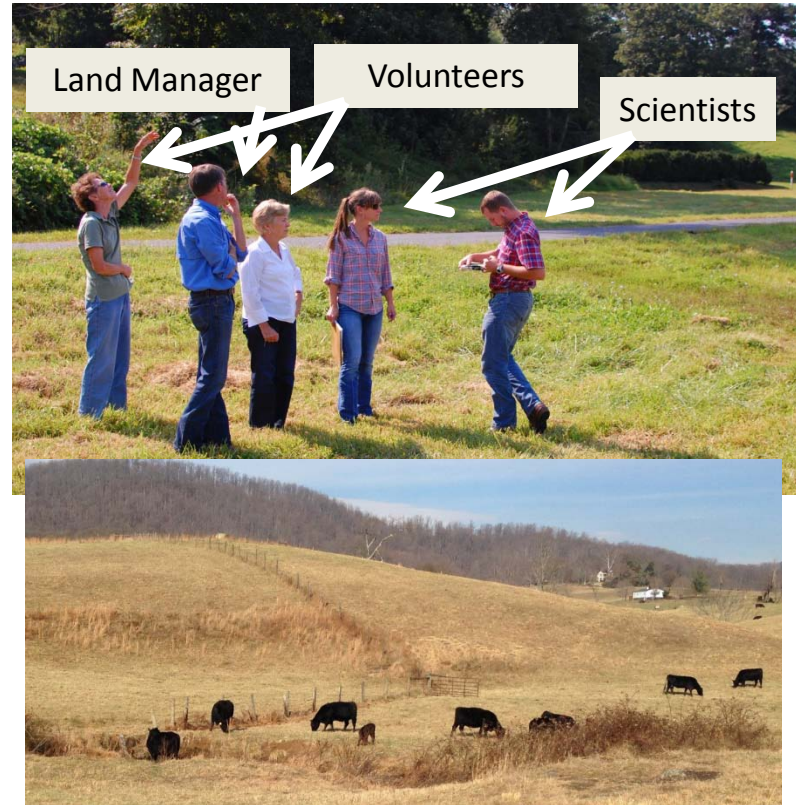

# Stream Protection

A local chapter of Virginia Master Naturalists volunteers interested in local land issues and developing an evidence-based management plan

Private land owners lease their land to farmers

Farmers who want to increase grazing capacity and economic benefits from cattle production

State agencies and land owners are concerned about water quality

**Research/Management Question:**  
How can management decisions balance environmental and economic needs?

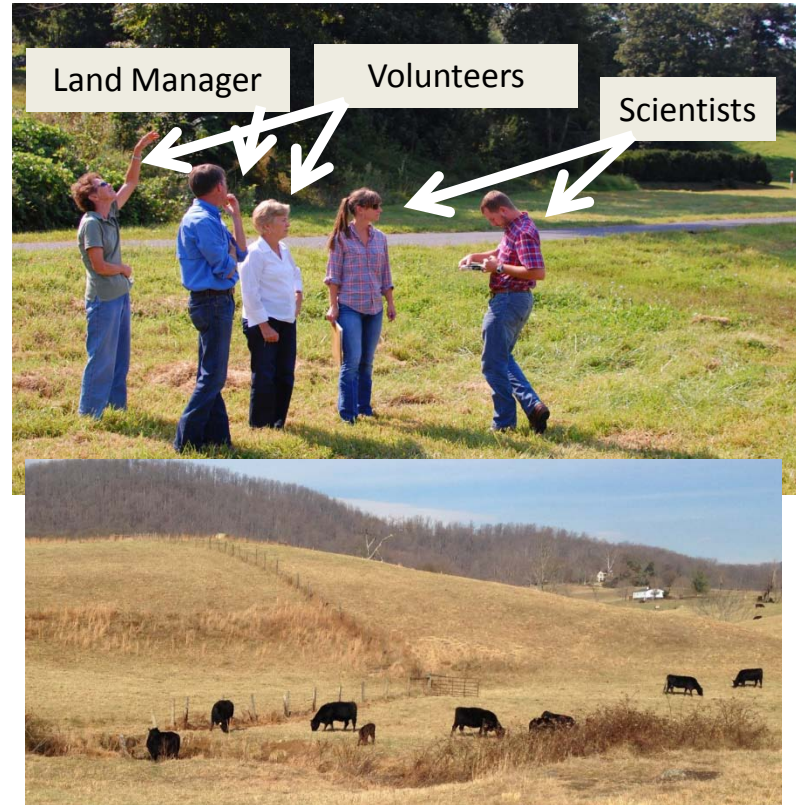



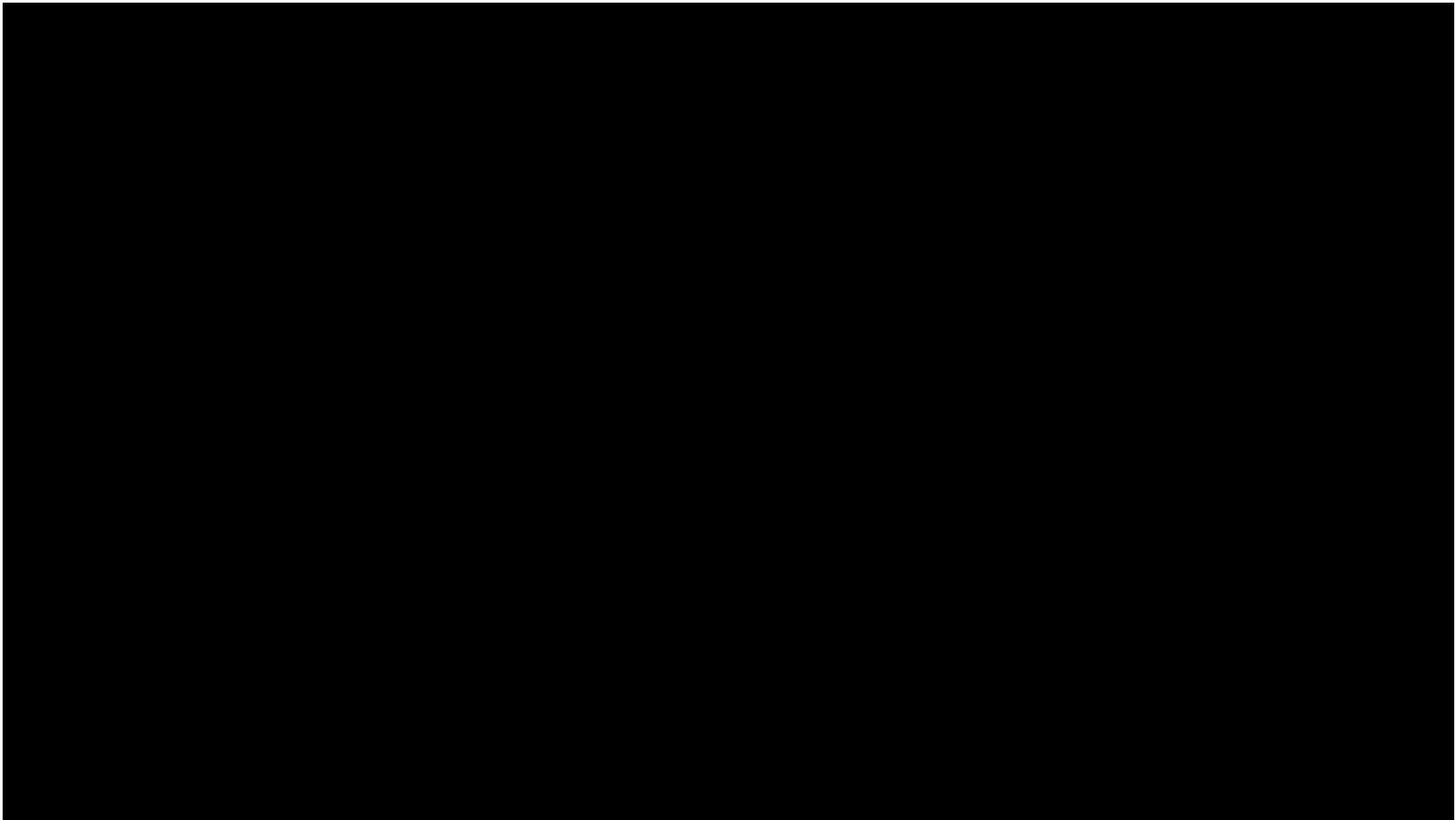

[http://www.youtube.com/watch?v=G5Cg56ahZJg&feature=em-upload\\_owner](http://www.youtube.com/watch?v=G5Cg56ahZJg&feature=em-upload_owner)

# Supporting the model with Evidence

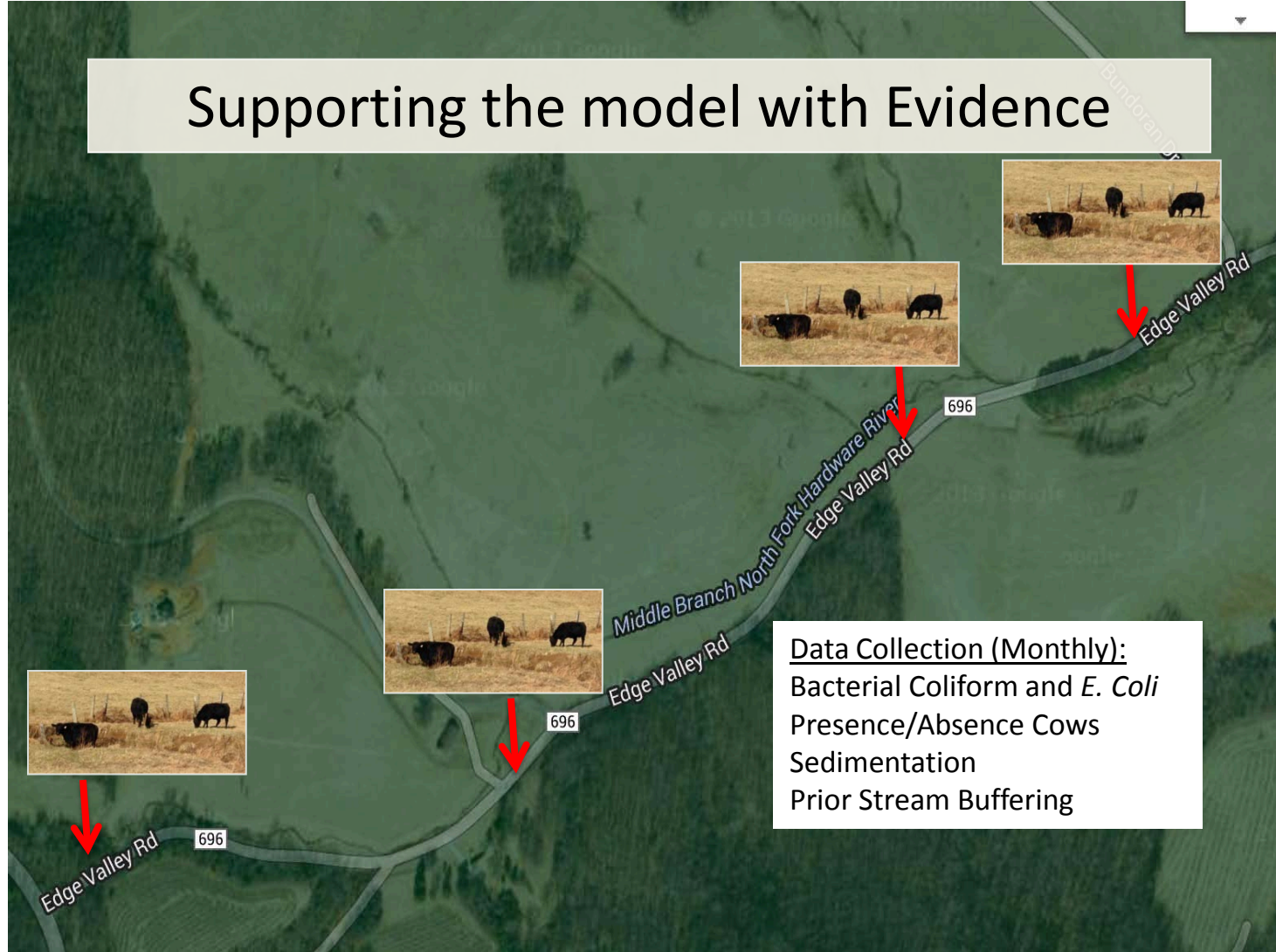

# Supporting the model with Evidence



Water Entering Property

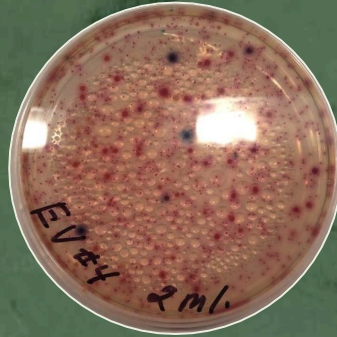

Water on Site

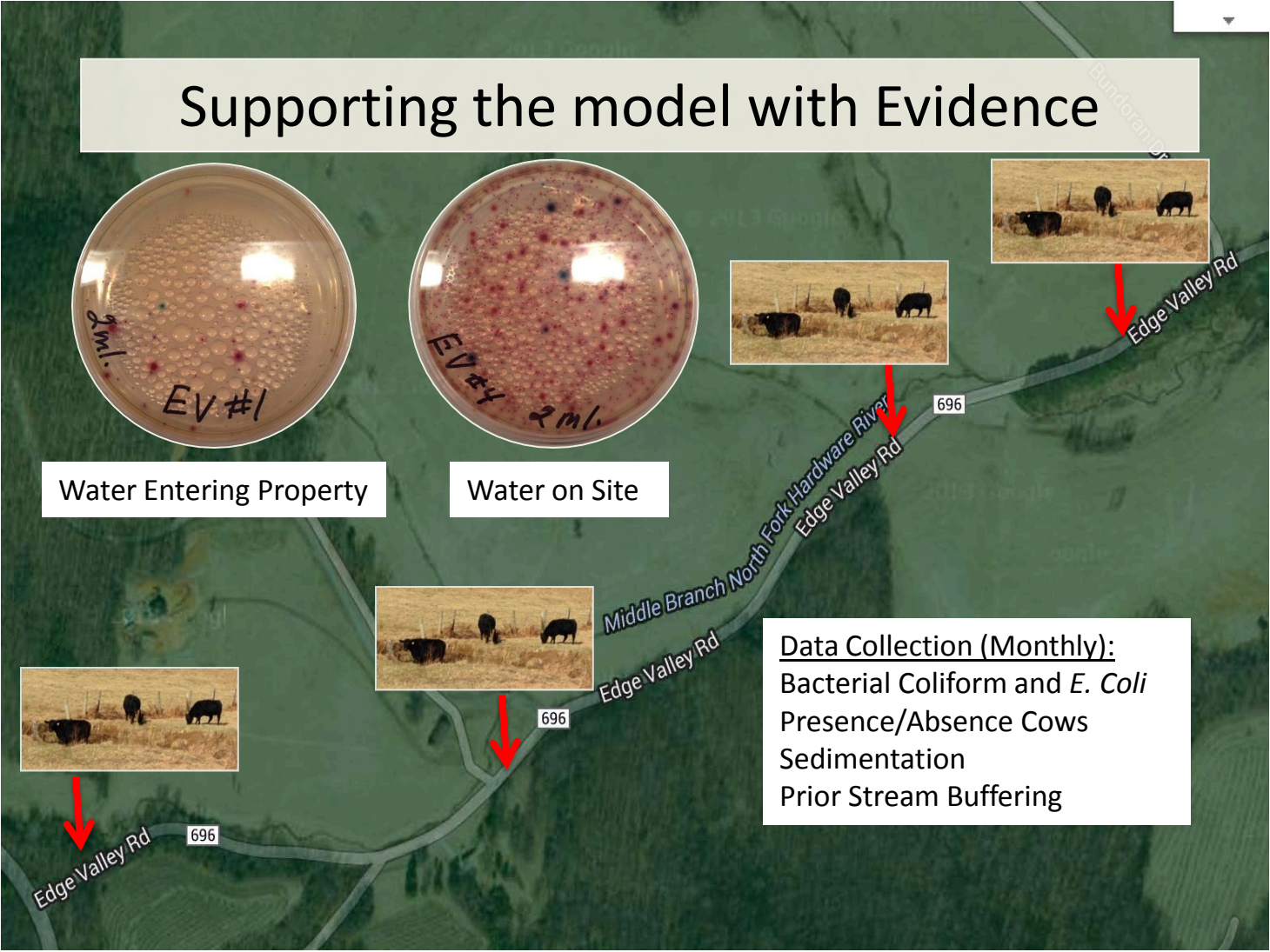

Data Collection (Monthly):  
Bacterial Coliform and *E. Coli*  
Presence/Absence Cows  
Sedimentation  
Prior Stream Buffering

# Supporting the model with Evidence

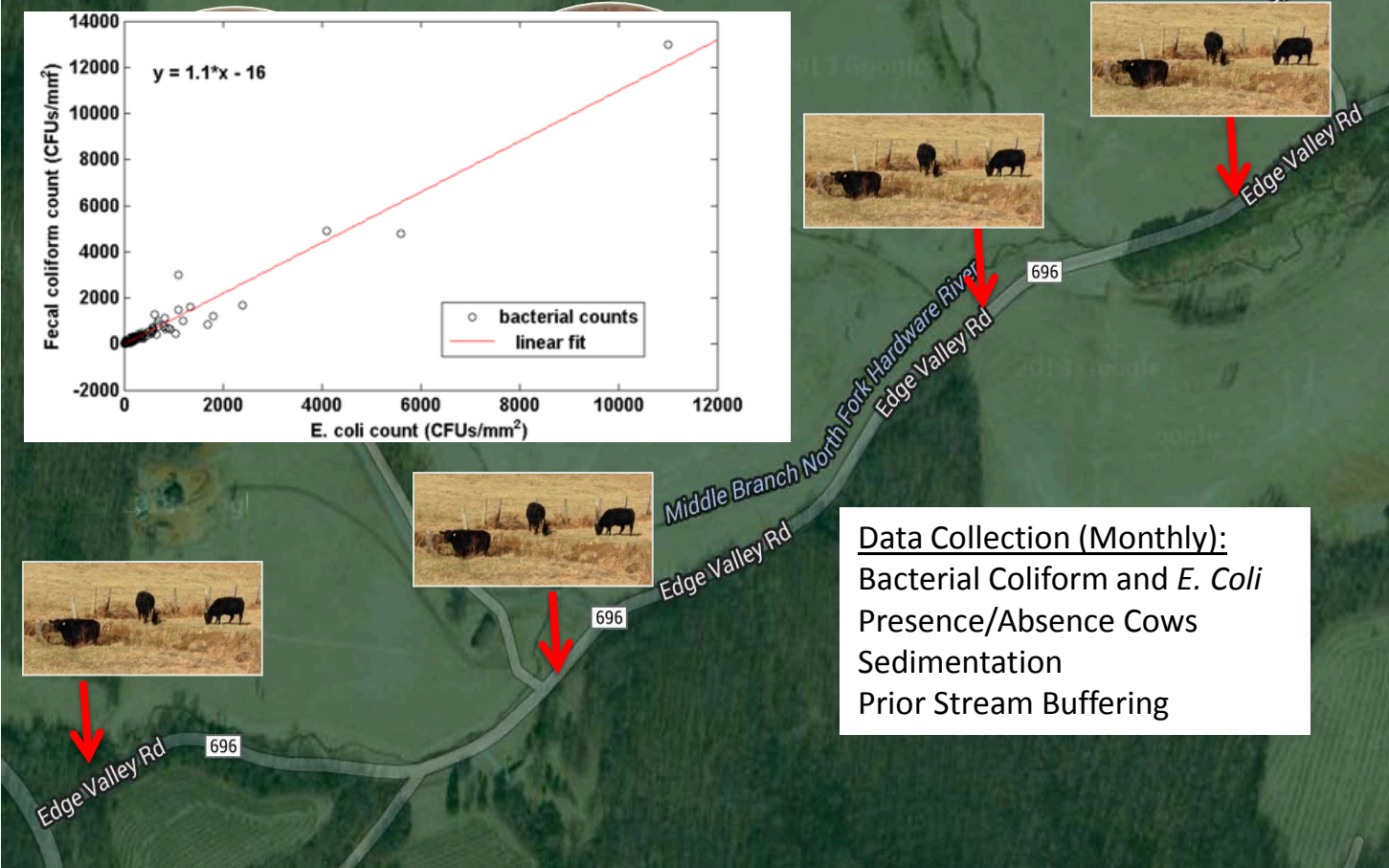
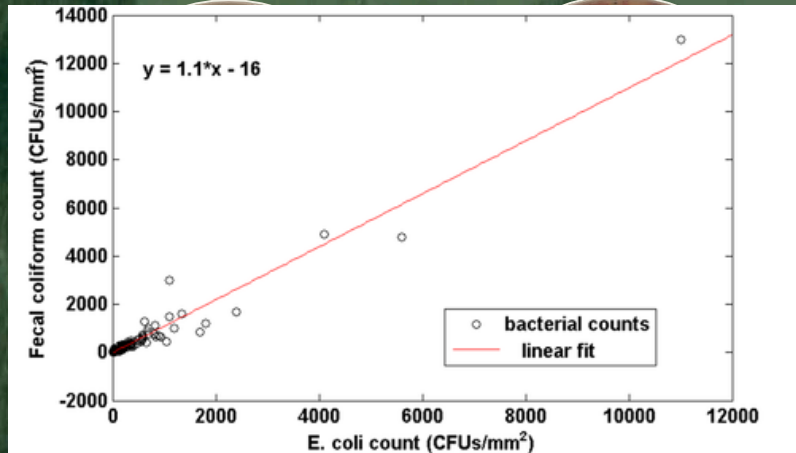

Data Collection (Monthly):  
Bacterial Coliform and *E. Coli*  
Presence/Absence Cows  
Sedimentation  
Prior Stream Buffering



# Outline

- Overview of Fuzzy-logic Cognitive Mapping
  - Fuzzy Numbers and Fuzzy Sets
  - Cognitive Mapping
  - Doing the calculations the old fashioned way:
    - Structural Metrics
    - Functional Metrics
- Introduction to *Mental Modeler*
  - *Case study of Collaborative Modeling for Citizen Scientists*
- New Analytical Capabilities coming soon!
  - Integrating MMP files into R
- Building a Model
  - *How do stakeholders view the relationship between logging, economic development and wildlife habitat?*



# Outline

- Overview of Fuzzy-logic Cognitive Mapping
  - Fuzzy Numbers and Fuzzy Sets
  - Cognitive Mapping
  - Doing the calculations the old fashioned way:
    - Structural Metrics
    - Functional Metrics
- Introduction to *Mental Modeler*
  - *Case study of Collaborative Modeling for Citizen Scientists*
- **New Analytical Capabilities coming soon!**
  - **Integrating MMP files into R**
- Building a Model
  - *How do stakeholders view the relationship between logging, economic development and wildlife habitat?*



# Introducing: FCM Scenario\*

R-Package with Shiny User Interface  
(still under development)



\*working title

# Objectives

- Provide **addition** to Mental Modeler (... and other FCM software)
- Enable complex FCM simulation and analysis - no programming background required
- Flexible: Open source code in R to facilitate further development
- Web-based: no need to install software
- Free



# R and Shiny



Image: BBC Bytesize

If <Variable 1> and  
<Variable 2>  
then  
Operation 1

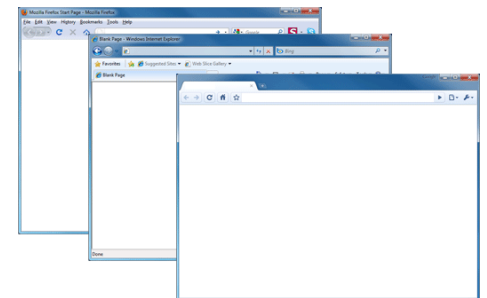

# Modeled after workflow

- Build FCM model / Knowledge Capture with Mental Modeler
- Refine FCM Model
- Define scenarios for simulation
- Run simulations
- Analyze and visualize results

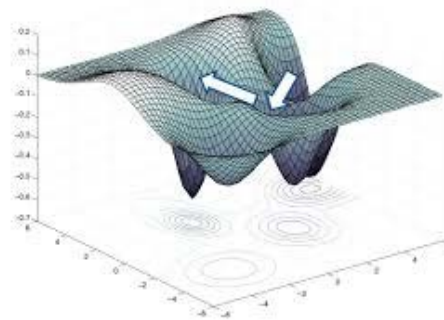

rstudio.cecs.pdx.edu:3838/users/kevin9/FCM/

Apps Image result for gla... Social Research Met... http://www.dodccrp... Save to Mendeley Save to Mendeley CS Knowledge Elicitatio... CAS - Universal Log... IB Home Import to Mendeley WM Tippspiel Other bookmarks

### Fuzzy Cognitive Maps

1.File Upload 2.FCM

Settings Concepts

**File Type:**  
MentalModeler

**File Location:**  
Local

**Choose File:**  
Choose File No file chosen

Upload

All Scenarios Individual Scenario Network Stats

Scenario Settings

Scenario Results

Scenario Plot

Select Scenarios to Plot:

Upload from Mental Modeler or .csv file

Fuzzy Cognitive Maps

1.File Upload 2.FCM

Settings Concepts

Start State: All One

Clamp Concept (Selected = Fixed):

Squashing Function: binary

Epsilon: 0

Max Iterations: 100

Queue

Download Model

All Scenarios Individual Scenario Network Stats

Scenario Settings

Scenario Results

Scenario Plot

Select Scenarios to Plot:

Define squashing function (binary, sigmoid, hyperbolic tangent, ...) for all concepts of each concept individually.  
In the near future: define your own squashing function

Fuzzy Cognitive Maps

1.File Upload 2.FCM

Settings Concepts

Start State:  
Specify

Clamp Concept (Selected = Fixed):  
C1-Awarness and Preperation Education  
C3-Natural Resource Protection/Adaptive Ecosystem  
C7-Loss of Property

Squashing Function:  
binary|  
binary  
tanh  
sigmoid  
All Above

100

Queue

Download Model

All Scenarios Individual Scenario Network Stats

Scenario Settings

Scenario Results

Scenario Plot

Select Scenarios to Plot:

“Clamp” Concepts

Define squashing function (binary, sigmoid, hyperbolic tangent, ...) for all concepts of each concept individually.  
In the near future: define your own squashing function

# Build interesting scenarios and run them together

Settings Concepts

Start State:  
All One

Clamp Concept (Selected = Fixed):  
C1-P1\nImprove Prevention and Suppression  
C4-P4\nPromote Community Assistance and Sharing of Responsibility

Squashing Function:  
sigmoid

All Scenarios Individual Scenario Network Stats

### Scenario Settings

scenario	s_state	fixed	squash	eps	iter
1	One	C1,C4	binary	0	100
2	One	C1,C4	tanh	0	100
3	One	C1,C4	sigmoid	0	100

Remove Last Clear Queue

### Scenario Results

Can be automated: Program finds all scenarios  
(Condition: concept states are 0 or 1 and weights are  
-1, 0, 1 )

# Show and compare results for each scenario

ITERATION	C1	C2	C3	C4	C5	C6	C7	C8	C9	C10	C11	C12	C13	C14	C15	C16	C17	C18	C19	C20	C21	C22	C23	C24	C25	C26	C27	C28	C29	C30	C31	C	
0	1	1	1	1	1	1	1	1	1	1	1	1	1	1	1	1	1	1	1	1	1	1	1	1	1	1	1	1	1	1	1	1	
1	1	0	0	1	0	-0.319	0	-0.319	0.319	-0.319	-0.319	0.007	0.319	0	0	0.319	0.319	-0.319	0	0	-0.93	0.001	0	0	-0.319	0.319	0.319	0.319	0	0	0.319	0	
2	1	0	0	1	0	-0.278	-0.179	-0.278	0.278	-0.278	-0.278	0.002	-0.221	0	0	0	0.108	0	0	0	0	0.309	0	0	-0.278	0.108	0	0	0	0	0	0	0
3	1	0	0	1	0	-0.001	-0.001	-0.001	0.001	-0.001	-0.001	-0.192	-0.319	0	0	0	0	0	0	0	0	-0.038	0	0	-0.001	0	0	0	0	0	0	0	0
4	1	0	0	1	0	0.083	0.083	0.083	-0.083	0.083	0.083	-0.33	-0.319	0	0	0	0	0	0	0	0	-0.109	0	0	0.083	0	0	0	0	0	0	0	0
5	1	0	0	1	0	0.108	0.108	0.108	-0.108	0.108	0.108	-0.349	-0.319	0	0	0	0	0	0	0	0	-0.109	0	0	0.108	0	0	0	0	0	0	0	0
6	1	0	0	1	0	0.115	0.115	0.115	-0.115	0.115	0.115	-0.349	-0.319	0	0	0	0	0	0	0	0	-0.109	0	0	0.115	0	0	0	0	0	0	0	0
7	1	0	0	1	0	0.115	0.115	0.115	-0.115	0.115	0.115	-0.349	-0.319	0	0	0	0	0	0	0	0	-0.109	0	0	0.115	0	0	0	0	0	0	0	0

Showing 1 to 6 of 6 entries

Previous 1 Next

## Iteration Plot

Select Concepts to Plot:

C1-P1(Improve Prevention and Suppression) C12-Wildfire C2-P2(Reduce Hazardous Fuel)  
C8-EB(Perceived Natural Beauty)

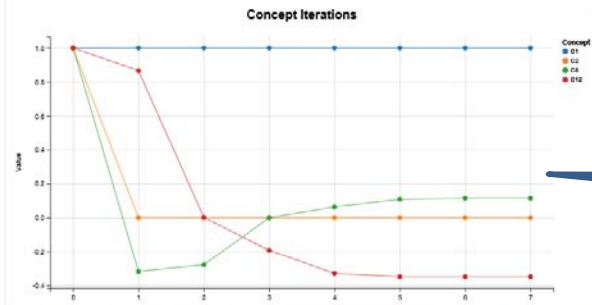

Analysis per concept

### Network Plot

Display Iteration:



Green (+ve), Blue (0), Red (-ve)

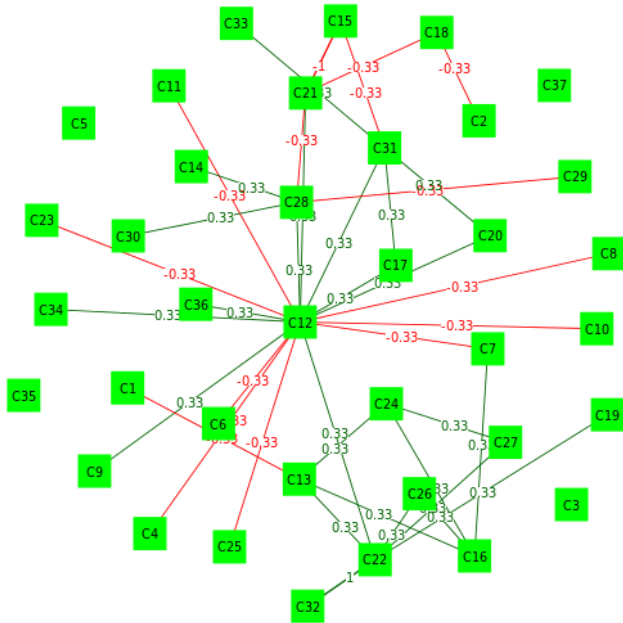

### Network Plot

Display Iteration:



Green (+ve), Blue (0), Red (-ve)

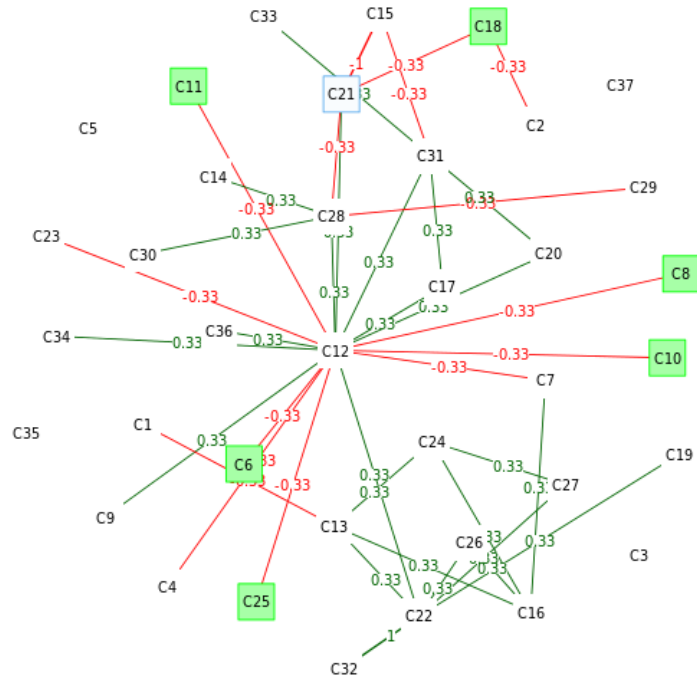



# Future plans and how you can help

- Test and further refine, go live (We need daring beta testers!)
- Document R package for further development (Collaborators welcome!)
- Please send e-mail if you want to stay informed: [ajetter@pdx.edu](mailto:ajetter@pdx.edu)

# Outline

- Overview of Fuzzy-logic Cognitive Mapping
  - Fuzzy Numbers and Fuzzy Sets
  - Cognitive Mapping
  - Doing the calculations the old fashioned way:
    - Structural Metrics
    - Functional Metrics
- Introduction to *Mental Modeler*
  - *Case study of Collaborative Modeling for Citizen Scientists*
- New Analytical Capabilities coming soon!
  - Integrating MMP files into R
- **Building a Model**
  - *How do stakeholders view the relationship between logging, economic development and wildlife habitat?*



# Modeling Logging in the Pacific Northwest



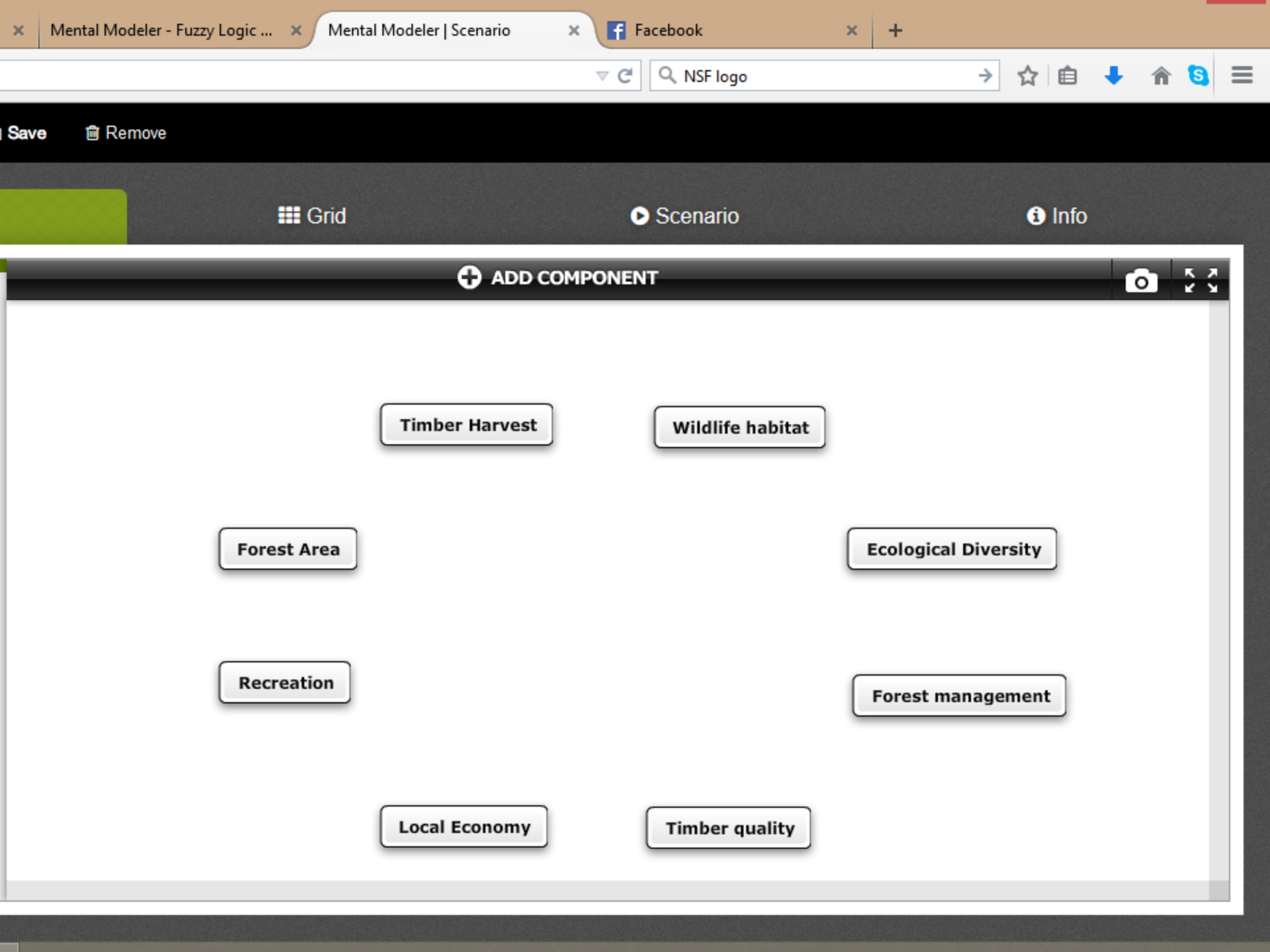

Save Remove

Grid

Scenario

Info

ADD COMPONENT

Timber Harvest

Wildlife habitat

Forest Area

Ecological Diversity

Recreation

Forest management

Local Economy

Timber quality

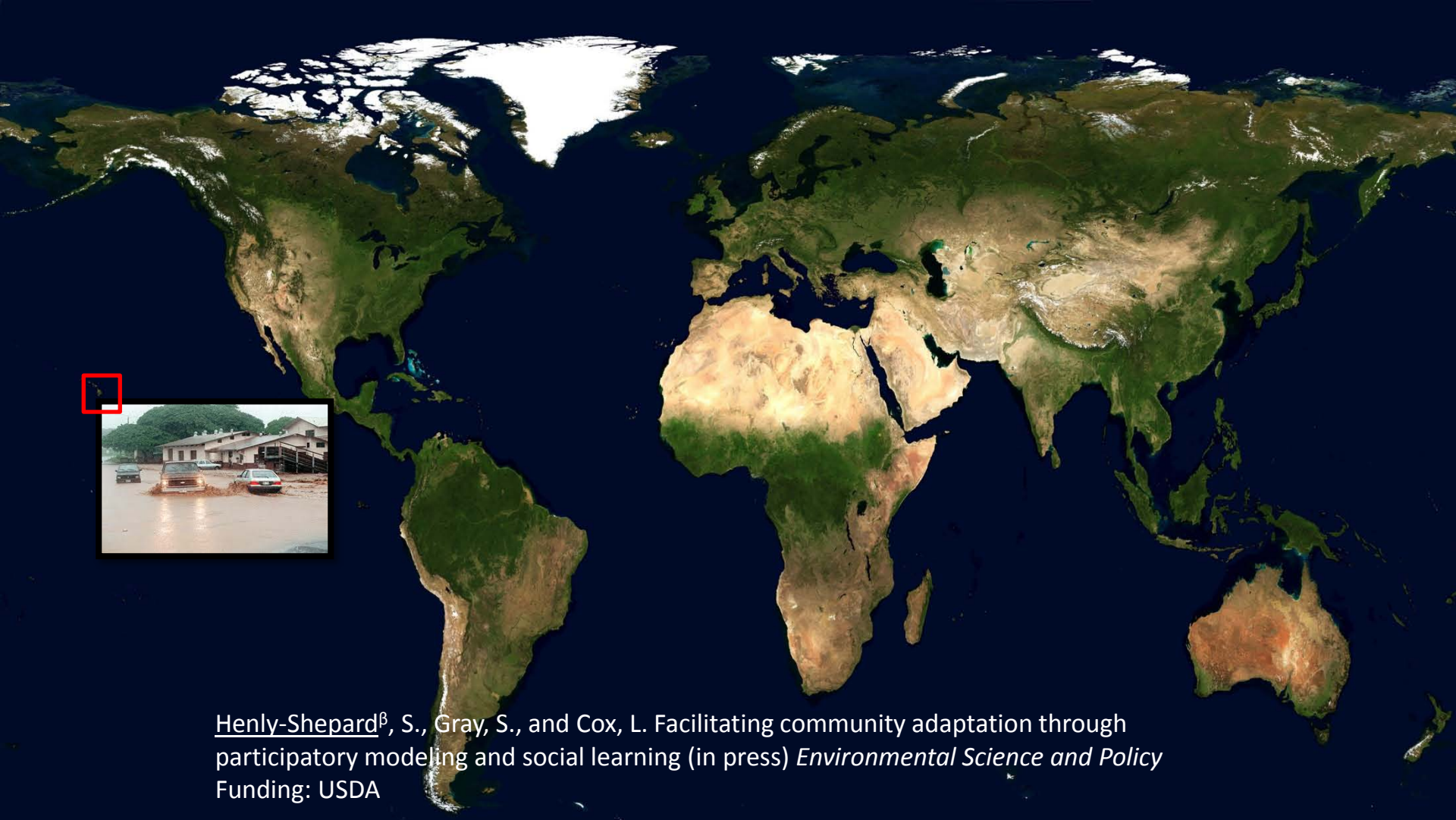

Henly-Shepard<sup>β</sup>, S., Gray, S., and Cox, L. Facilitating community adaptation through participatory modeling and social learning (in press) *Environmental Science and Policy*  
Funding: USDA





Stier, A., Samhouri, J., Levin, P., Gray, S., Martone, R. and Mach., M. Differences in perception, not (necessarily) values can produce conservation conflict. (in review) *Proceedings of the National Academy of Science*.

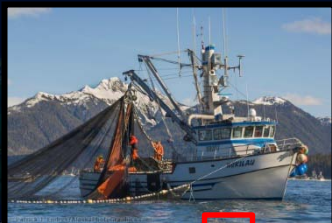

Gray, S., Gagnon, A., Gray, S., Mahony, C., Muir, D., Falaleeva, M. 2014. Are local coastal managers detecting the problem? Assessing stakeholder perception of climate vulnerability using Fuzzy Cognitive Mapping. *Ocean and Coastal Management*. 94:74-89





Gray, S., McFall, A., Hilsberg, J., Arlinghaus, R. 2015. The impact of specialization and target species choice on the structure of mental models about fish population dynamics (in press) *Journal of Outdoor Recreation and Tourism*.





Nayaki<sup>β</sup>, A., Gray, S., Lepczyk, J. Skibins, D. Rentsch. 2014. Understanding the hidden drivers and local-scale dynamics of the bushmeat trade through participatory modeling *Conservation Biology* 28(5) 1403-1414. Funding: Frankfurt Zoological Society



Halbrendt<sup>β</sup>, J., Gray, S., Radovich, T., Crow, S., and A. Kimura, A. 2014. Differences in farmer and expert beliefs about the perceived impacts of conservation agriculture. *Global Environmental Change*. 28: 50-62.



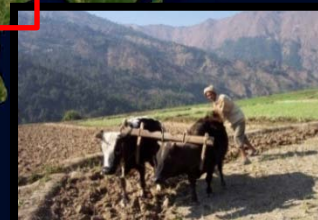

NSF (Belmont Forum)  
Agriculture, Food Security & Climate Change : *Sustainable Management of Agro-ecological Resources for Tribal Societies*

Academic: 76%  
Government: 13%  
NGO: 11%

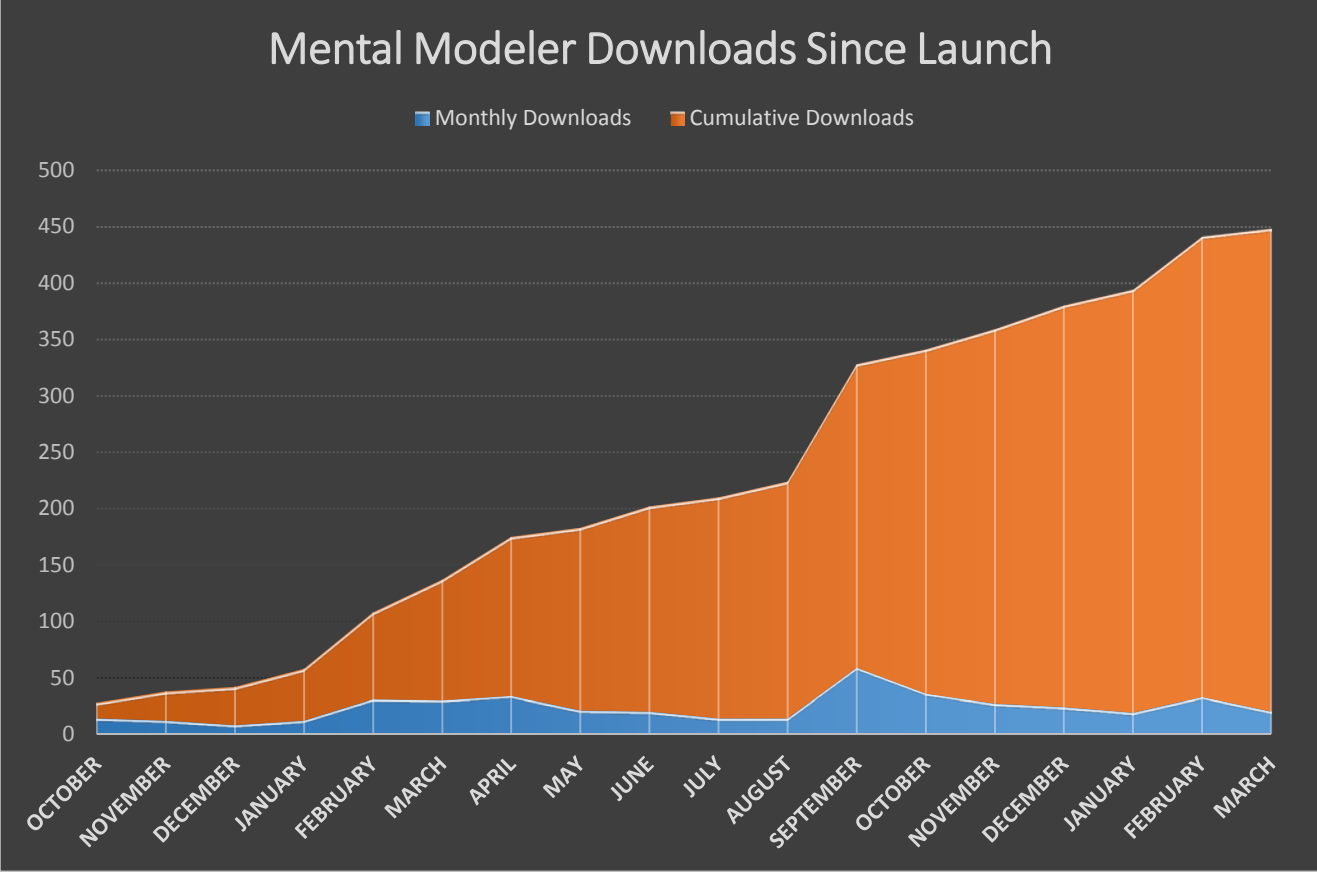



Thanks for coming!

[stevenallangray@gmail.com](mailto:stevenallangray@gmail.com)

[ajetter@pdx.edu](mailto:ajetter@pdx.edu)